

Unit 4

Composite Figures and Area of Trapezoids

Grade 7

Lesson Outline

Big Picture

Students will:

- investigate, develop a strategy to find the area of and solve problems involving trapezoids;
- apply number sense and numeration knowledge to measurement problems. (e.g., multiplication and division of whole numbers and decimals, estimation, order of operations);
- determine the characteristics of a right prism;
- determine the surface area of and solve problems involving the surface area of right prisms;
- understand perfect squares and square roots;
- research and report on applications that involve area measurements and calculations.

Day	Lesson Title	Math Learning Goals	Expectations
1	2-D or 3-D?	<ul style="list-style-type: none"> Distinguish between 2-D shapes and 3-D figures. Estimate areas of triangles and quadrilaterals. Consolidate understanding of perimeters and areas of triangles, rectangles, and parallelograms. 	7m21, 7m22, 7m39 CGE 3c, 4a, 4f
2	Areas of Composite Shapes	<ul style="list-style-type: none"> Understand why area is measured in square units. Decompose composite shapes into known shapes. Understand that the total area of a shape is equal to the sum of areas of its smaller parts (using more than one way). Determine the area of composite shapes. 	7m17, 7m21, 7m22, 7m23, 7m33, 7m39 CGE 3c, 4b
3	Using Exponential Notation and Estimation to Calculate Area	<ul style="list-style-type: none"> Relate exponential notation and the measurement of area, e.g., a square with sides of 7 cm has area 7×7 or 49 cm^2. Measure a variety of rectangles, parallelograms, and triangles found in composite figures using the metric system. Estimate areas, then calculate areas. 	7m17, 7m21, 7m22, 7m23, 7m36, 7m39 CGE 3c
4	Developing Metric Relationships Used in Measuring Lengths and Areas	<ul style="list-style-type: none"> Understand when smaller units to measure area are more appropriate than larger units (and vice versa). Determine the relationship of metric lengths when they are converted to larger or smaller units of length, e.g., how many centimetres in one kilometre? When might you need to know the smaller/larger measure? Understand the relationship of metric areas when they are converted to larger or smaller units of area, i.e., draw a diagram of a square metre, divide it into square centimetres to determine how many square centimetres are contained in one square metre. 	7m20, 7m35, 7m36 CGE 3c
5	Metric Conversions of Length and Area	<ul style="list-style-type: none"> Convert between metric units of area, i.e., square centimetres to square metres, etc. Solve everyday problems that require conversion of metric area measures. 	7m20, 7m21, 7m22, 7m35, 7m36 CGE 3c
6	What Is a Trapezoid?	<ul style="list-style-type: none"> Understand the definitions and characteristics a trapezoid. Make a graphic organizer and/or a Venn diagram that shows different polygons, and in particular, different quadrilaterals, including trapezoids. 	7m37, 7m39 CGE 3c
7	Investigating Areas of Trapezoids	<ul style="list-style-type: none"> Investigate ways to determine the area of a trapezoid. Develop strategies for finding the area of a trapezoid. 	7m23, 7m37, 7m39 CGE 4f

Day	Lesson Title	Math Learning Goals	Expectations
8	How to Trap a Zoid with The Geometer's Sketchpad [®] 4	<ul style="list-style-type: none"> Construct points, segments, parallel lines, and shapes, using The Geometer's Sketchpad[®]4 Practise constructing and measuring trapezoids, using The Geometer's Sketchpad[®]4. 	7m46, 7m47 CGE 3c, 5a
9	Reducing Taxes	<ul style="list-style-type: none"> Understand that a trapezoid can have zero or two right angles. Develop the formula for the area of a trapezoid containing two right angles. 	7m23, 7m37, 7m38, 7m39 CGE 2b, 4e
10	Paying Taxes	<ul style="list-style-type: none"> Develop a formula to calculate the area of any trapezoid. 	7m23, 7m37, 7m38, 7m39 CGE 3b, 3c, 5a, 5g
11	Applying Knowledge About Trapezoids	<ul style="list-style-type: none"> Solve problems involving the area of trapezoids. 	7m21, 7m22, 7m23, 7m38 CGE 2b, 3c, 4f
Term 2			
12	Investigating Right Prisms	<ul style="list-style-type: none"> Investigate to determine the characteristics of right prisms. Identify and build a variety of right prisms, e.g., with bases that are squares, rectangles, triangles, parallelograms, and trapezoids. 	7m49 CGE 4c, 5a
13	Surface Area of Rectangular Prisms	<ul style="list-style-type: none"> Develop a method for finding the surface area of a rectangular prism. 	7m41, 7m42 CGE 5a, 3c
14	Surface Area of Triangular Prisms <i>GSP[®]4 file: PrismsNets</i>	<ul style="list-style-type: none"> Develop a method for finding the surface area of a triangular prism. Solve problems involving the surface area of triangular prisms. Solve problems that require conversion between metric units of area. 	7m20, 7m21, 7m22, 7m23, 7m36, 7m41, 7m42 CGE 4b, 2c
15	Surface Area of Right Prisms with Parallelogram Bases	<ul style="list-style-type: none"> Determine the surface area of right prisms with parallelogram bases using concrete materials. Solve problems involving surface area of right prisms with parallelogram bases. 	7m21, 7m22, 7m23, 7m36, 7m41, 7m42 CGE 2b, 3c
16	Surface Area of Right Prisms with Trapezoid Bases	<ul style="list-style-type: none"> Determine the surface area of right prisms with trapezoidal bases using concrete materials. Solve problems involving surface area of right prisms with trapezoid bases. 	7m21, 7m22, 7m23, 7m41, 7m42 CGE 2b, 3c
17	Surface Area of Prisms Whose Bases Are Composite Figures	<ul style="list-style-type: none"> Build prisms with bases that are composite figures. Develop a method to calculate surface area of prisms with bases that are composite figures. Solve problems that require conversion between metric units of area. 	7m20, 7m21, 7m22, 7m23, 7m36, 7m41, 7m42 CGE 2c, 5a
18	Surface Area of Right Prisms	<ul style="list-style-type: none"> Demonstrate understanding of surface area of prisms with polygon bases. 	7m21, 7m22, 7m23, 7m42 CGE 3a, 3c

Day	Lesson Title	Math Learning Goals	Expectations
19	Perfect Squares and Their Square Roots	<ul style="list-style-type: none"> Use the area of a square to represent perfect squares and square roots, using geoboards and grid paper. Relate square root to the side of a square with area that is a perfect square number, e.g., connect a square with area 49 cm^2 and side length 7 to the square root of 49 being 7. Create the pattern of perfect squares (e.g., 4, 9, 16, 25, 36, 49...) and their square roots. 	7m16, 7m17 CGE 3c, 2c
20	Square Roots of Non-Perfect Squares	<ul style="list-style-type: none"> Given the area of a square with sides that are not perfect square measures, estimate and calculate the length of the sides. Relate to estimating the square roots of non-perfect squares, e.g., the square root of 50 will be slightly more than the square root of 49. Use a calculator to determine exact values for square roots of non-perfect squares. 	7m16, 7m17 CGE 3c, 4b
21– 23	Applications of Area Measurements	<ul style="list-style-type: none"> Research and report on everyday applications of area measurements (in the form of a project). 	7m20, 7m21, 7m22, 7m23, 7m33, 7m42 CGE 4e, 4f, 4g

**Math Learning Goals**

- Distinguish between 2-D shapes and 3-D figures.
- Estimate areas of triangles and quadrilaterals.
- Consolidate the characteristics of perimeters and areas of triangles, rectangles, and parallelograms.

Materials

- cm grid paper
- sticky notes
- geometric models
- BLM 4.1.1, 4.1.2

Assessment Opportunities**Minds On...****Individual → Review**

Show some 2-D shapes and 3-D figures and name them.

Students complete BLM 4.1.1. Clarify any concerns that students raise.

Pairs → Activate Prior Knowledge

Each pair selects one shape from the list (question 2, BLM 4.1.1). They sketch the shape(s) chosen and write one or two properties of the shape that are not included in its definition. Post the notes on a Know/Want to Know/Learn classroom chart. Read aloud and discuss the students' responses of terms.

Action!**Pairs → Investigation**

Students investigate perimeter and area of 2-D shapes (BLM 4.1.2).

Communicating/Observation/Rating Scale: Focus on fluent, accurate, and effective use of mathematical vocabulary.

Consolidate Debrief**Whole Class → Discussion**

Students explain how they estimated the areas of the various shapes. They could tell that they decomposed larger shapes into simple shapes such as right triangles. Others may explain how a right triangle is half of a rectangle.

Review area and perimeter formulas. Post these formulas.

Students demonstrate how they applied the area formulas. Encourage all possible answers and ask whether they think there is more than one method of solving these types of problems. Check answers using overhead transparency.

Home Activity or Further Classroom Consolidation

- In his description of the dinner, Gulliver confused some two-dimensional shapes with three-dimensional figures. Make a list of the two-dimensional shapes he named and another list of the three-dimensional figures. Then rewrite Gulliver's first paragraph using the appropriate terms.

OR

- Use two-dimensional and three-dimensional shapes and figures to present Gulliver's dinner. Label each shape and figure.

OR

- Write a sentence and draw a sketch to explain the meaning of each term. You may need to use a dictionary.
 - parallelogram
 - trapezoid
 - equilateral triangle
 - rhombus
 - rectangular prism
 - triangular prism

(Adapted from Impact Math – Measurement)

Have models of geometric objects prominently on display.

Word Wall

- 2-D shapes
- 3-D figures
- parallelogram
- trapezoid
- equilateral triangle
- rhombus
- rectangular prism
- triangular prism

Concept Practice Reflection

4.1.1: 2-D or 3-D?

Name:

Date:

Think about two-dimensional (2-D) shapes and three-dimensional (3-D) figures. A 2-D shape, such as a triangle, lies on a flat surface while a 3-D figure, such as a rectangular prism, projects above or below the surface.

- Write names of the following geometric objects in the correct column of the table:
rhombus, right triangle, cylinder, parallelogram, triangular prism, square, cone, polygon,
rectangle, sphere, circle, quadrilateral, pyramid, scalene triangle

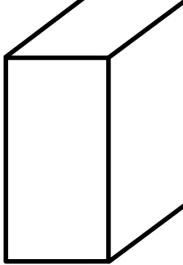
	Two-Dimensional Shapes	Three-Dimensional Figures
 Triangle (2-D)		
		 Rectangular Prism (3-D)

- Draw a line from each 2-D shape name to its definition. Some definitions could represent more than one shape so select the most appropriate definition in each case.

Polygon	A quadrilateral with both pairs of opposite sides parallel
Triangle	A three-sided polygon
Quadrilateral	A rectangle with all four sides equal
Parallelogram	A 2-D closed shape whose sides are straight line segments
Rectangle	A quadrilateral with all four sides equal
Rhombus	A four-sided polygon
Square	A quadrilateral with four right angles and both pairs of opposite sides equal

4.1.2: Gulliver Dines with the Mathematicians

(Source: Impact Math – Measurement)

Gulliver's Travels is a popular tale of a traveller named Gulliver who sailed the oceans to strange and distant lands. Most people know of his visit to Lilliput, the land of the little people. Some know of his visit to Brobdingnag, island of the giants. But few have read the chapter about Gulliver's visit to Laputa, the land of the mathematicians. Some small excerpts from that visit are presented here in a slightly modified form, to modernize the old English in which this manuscript was written almost three centuries ago!

"We had two courses of three dishes each. In the first course, there was a shoulder of mutton [lamb], cut into an equilateral triangle; a piece of beef into a rhombus and a pudding into a cycloid [cone] ... The servants cut our bread into cones, cylinders, parallelograms and several other mathematical figures ... Their ideas are perpetually expressed in lines and figures. To praise the beauty of an animal, they describe it in terms of rhombuses, circles, parallelograms, ellipses and other geometric terms."

1. Name the 2-dimensional shapes drawn on the centimetre grid below. Count squares to estimate the perimeter and area of each. Record your estimates.

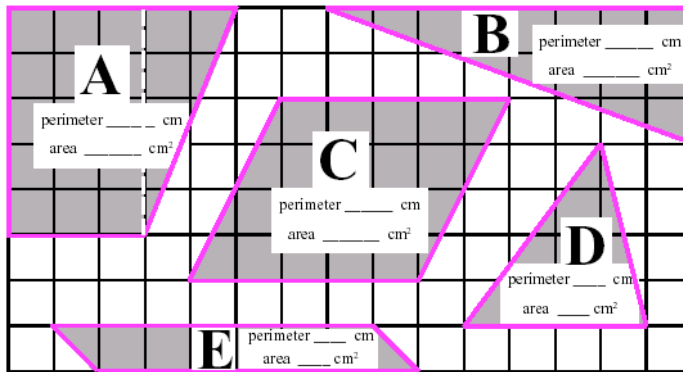

Shape	Name of Shape	Estimated Perimeter	Estimated Area	Calculated Area
A				
B				
C				
D				
E				

4.1.2: Gulliver Dines with the Mathematicians (continued)

2. Write as many of these area formulas as you know.
 - a) The area of a rectangle given its length l and width w .
 - b) The area of a triangle given its height h and the length b of its base.
 - c) The area of a parallelogram given the length l of one side and the perpendicular distance d from it to the other parallel side.

Use the formulas you know to check your estimates of the area of each shape in question 1. Reflect on how accurate your estimates were.

3. Draw each of these 2-dimensional shapes on cm grid paper.
 - a) a rectangle of area 20 cm^2 and perimeter 18 cm .
 - b) a parallelogram of area 24 cm^2 and perimeter 22 cm .
 - c) a quadrilateral of area 20 cm^2 and perimeter 20 cm .



Math Learning Goals

- Understand why area is measured in square units.
- Decompose composite shapes into known shapes.
- Illustrate that the total area of a shape is equal to the sum of areas of its smaller parts (using more than one way).
- Determine the area of composite shapes.

Materials

- tangram sets
- grid paper
- overhead grid
- BLM 4.2.1, 4.2.2

Assessment Opportunities



Minds On...

Whole Class → Sharing

Selected students share their Home Activity from Day 1. Include one or two students for each of the three choices.

Curriculum Expectations/Quiz/Marking Scheme: Use a short quiz to assess students' understanding of calculating area for various shapes.



Action!

Whole class → Guided Problem Solving

Guide students to see different ways to calculate areas of composite shapes on BLM 4.2.1. Discuss when each process may be most appropriate.

Ask:

- Could you use symmetry to find the area of any of the shapes?
- Which shapes?
- How do you know?

Demonstrate different subdivisions on an overhead.

Model the processes and form of written communication to show the solution for one of the shapes on BLM 4.2.2.

Think/Pair/Share → Practice

Using grid paper, partners work together to create a composite shape, then subdivide and find areas individually, and compare results. Students should use different ways to find the area.

Individual → Practice

Students complete BLM 4.2.2.

Students subdivide the various shapes and present their illustrations on the board.

Problem Solving/Presentation/Anecdotal Note: Assess students' ability to see different ways of sub-dividing the shapes and applying the formulas correctly.



Consolidate Debrief

Individual → Response Journal

Students make entries in their math journals based on prompts such as:

- I can tell area and perimeter measurements apart by...
- Areas of triangles and rectangles are related in this way
- The areas of composite shapes can be calculated by...
- When finding area of shapes without right angles...

Pose the question: Does it make sense to add the perimeters of the parts of a composite figure together to find the total perimeter? Write an explanation to communicate your thinking.

Students share responses.

Home Activity or Further Classroom Consolidation

Locate some composite shapes for which you could find the area and perimeter, e.g., lawn, carpet in a non-rectangular room. Make a sketch, measure, and record dimensions on the sketch, and find the perimeter and area.

Explain the difference between area and perimeter to someone at home and ask them to provide feedback on the clarity of your explanation.

Concept Practice Reflection

Students may suggest processes that might involve either subdividing the shape into familiar shapes or extending the figure into a quadrilateral and subtracting missing area.

Subsequent steps include:

- taking needed measurements;
- representing symbolically, substituting into formulas, then computing;
- noting appropriate units.

Encourage different strategies. Compare solutions. Pay particular attention to the written form of the solution.

4.2.1: Subdividing Composite Shapes

Name:

Date:

Subdivide each shape into shapes for which you know an area formula.
Do this in more than one way.

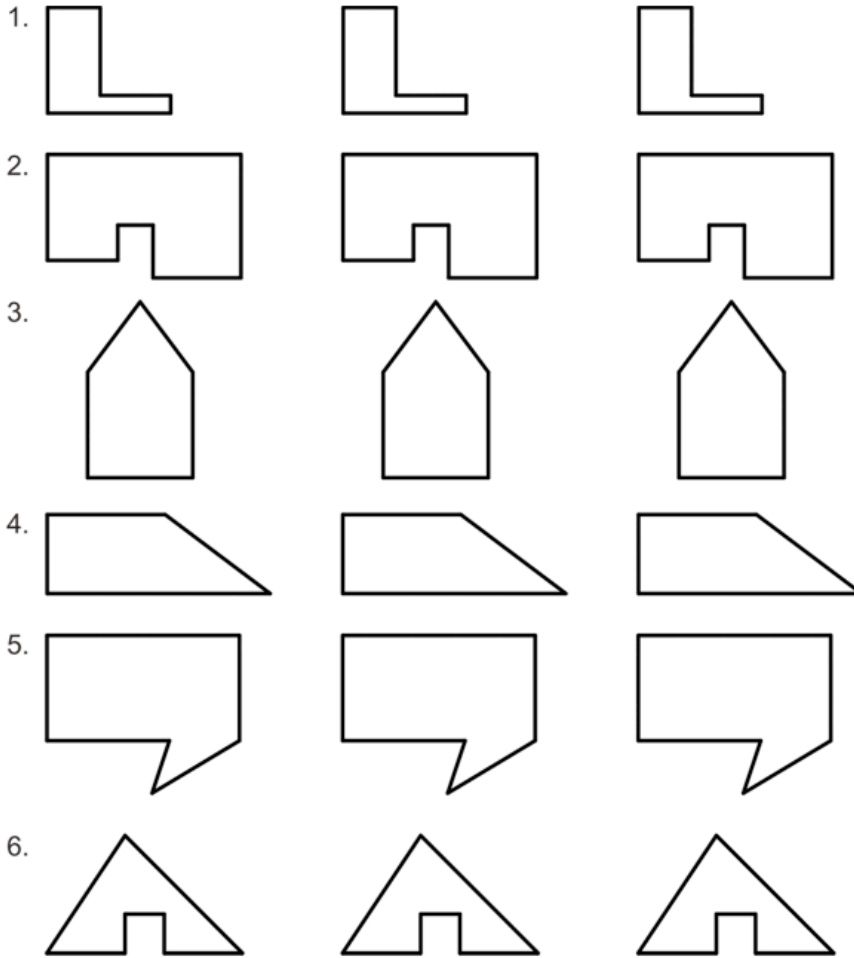

4.2.2: Subdividing Composite Shapes Guide

Name:

Date:

Find the area of each shape by subdividing it into shapes for which you know the formula. Do this in more than one way.

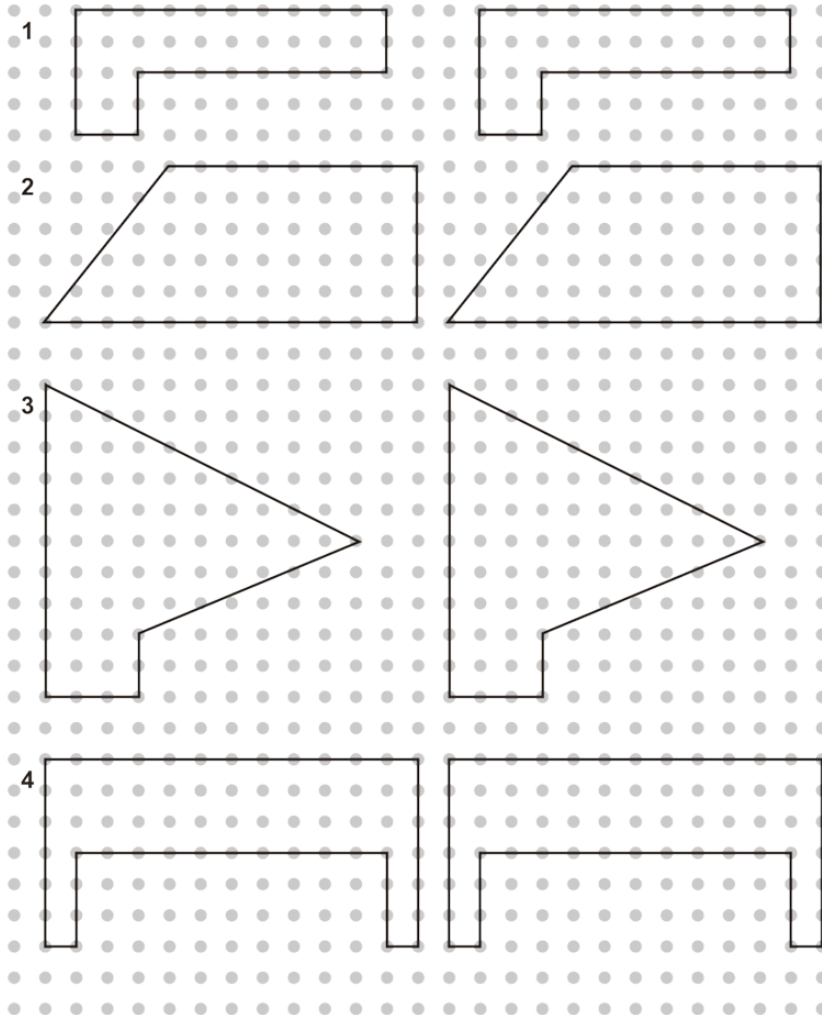

Find the area of this shape by:

- a) visualizing the addition of subdivisions
- b) visualizing the subtraction of areas
- c) using symmetry

	<p>Math Learning Goals</p> <ul style="list-style-type: none"> • Students will relate exponential notation and the measurement of area, e.g. a square with side lengths of 7cm has area 7×7 or 49 cm^2 • Students will measure a variety of rectangles, parallelograms, and triangles found in composite figures using the metric system • Students will estimate areas, then calculate areas 	<p>Materials</p> <ul style="list-style-type: none"> • BLM 4.3.1 • BLM 4.3.2 • Tangrams • Graph Paper • Rulers
<p>Minds On...</p>	<p>Small Groups → Activity</p> <p>Handout envelopes with cut out tangram shapes from BLM 4.3.1 to each group.</p> <p>Write the following instructions on the board:</p> <ol style="list-style-type: none"> 1. Use a ruler to make necessary measurements to help you calculate the area of each piece of your tangram. 2. Construct a square using all of the tangram pieces. 3. Using a ruler make necessary measurements to determine the area of the new square <p>Remind your students to use exponential notation when stating the units in their answers!</p> <p>Whole Class → Discussion</p> <p>Pose this question to students: If one shape is removed from the tangram set, how could you determine the new area?</p>	<p>Provide students who have difficulty making the square with a copy.</p> <p>Can students find the area of each of the known shapes?</p>
<p>Action!</p>	<p>Pairs → Investigation</p> <p>Instruct students to choose a tangram puzzle card from BLM 4.3.2 and write an estimate the area of the tangram in cm^2.</p> <p>Students should discuss with their partner different ways of dividing the tangram into known 2D shapes. They should then decide on what they consider to be the best division and justify their choice.</p> <p>Using the known shapes, students should determine the area of their tangram by measuring appropriate side lengths. And present their calculations using some method of organization on a piece of paper.</p>	<p>Students chose which tangram to work with. You may wish to assign less complicated tangrams to struggling students</p>
<p>Consolidate Debrief</p>	<p>Whole Class → Presentations</p> <p>Have volunteers present their findings. Remind them to explain why they choose to divide their tangram the way they did and compare their results to their original estimate.</p> <p>Individual → Journal Response</p> <p>Students will respond to the following question, in a journal:</p> <p>If you knew the area of one known shape in the tangram how could you use that to help you estimate the area of the other pieces?</p>	
<p><i>Exploration</i></p>	<p>Home Activity or Further Classroom Consolidation</p> <p>Create your own tangram puzzle and determine the area of the puzzle.</p>	

4.3.1: Constructing a Tangram from a Square Pattern

Grade 7

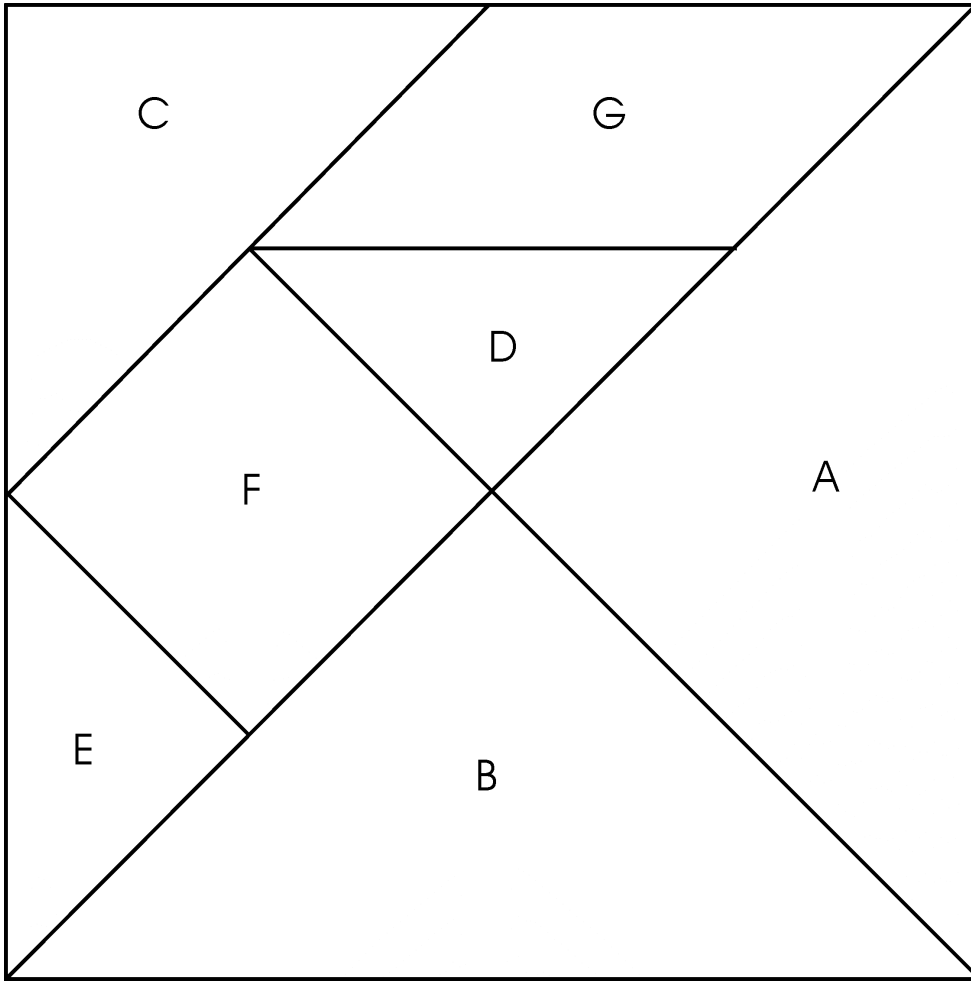

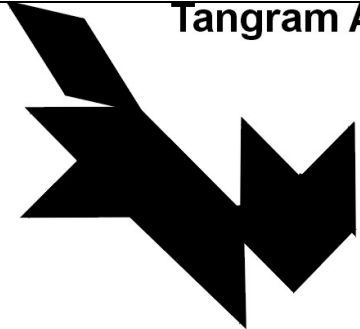
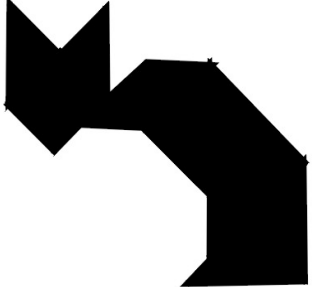
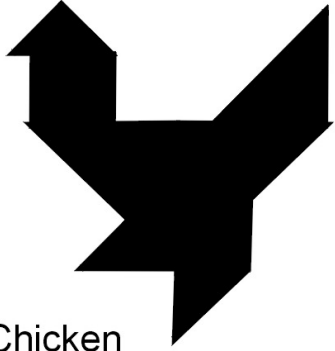
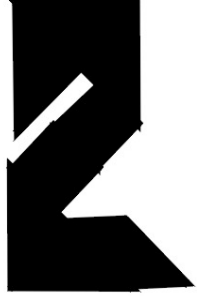
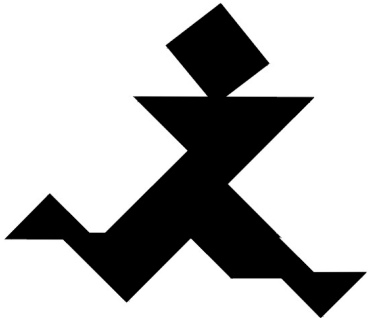
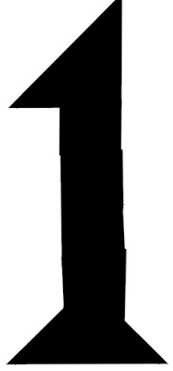
Tangram Animal	
 <p>Fox</p>	 <p>Cat</p>
 <p>Chicken</p>	
 <p>Runner</p>	

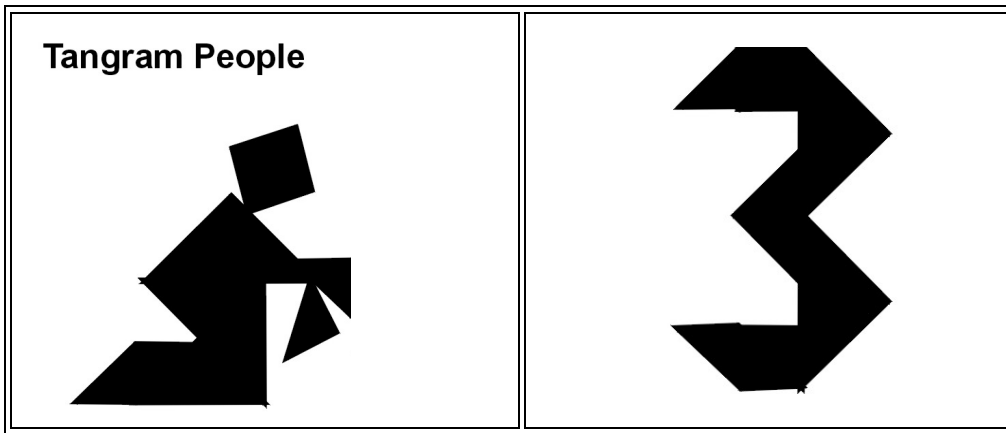

Possible solutions for dividing up each tangram

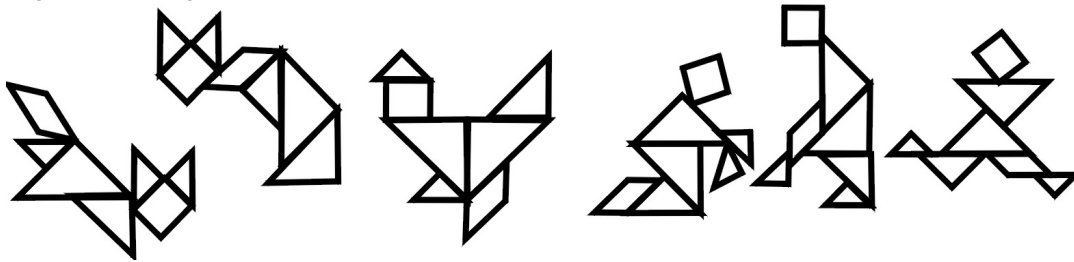

Unit 4: Day 4: Developing Metric Relationships Used in Measuring Lengths and Areas

Grade 7

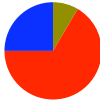
	<p>Math Learning Goals</p> <ul style="list-style-type: none"> • Students will understand when using smaller units to measure area is more appropriate than using larger units (and vice versa). • Students will determine the relationship of metric lengths when they are converted to larger or smaller units of length, e.g. how many centimetres are in one kilometre? When might you need to know the smaller/larger measure? • Students will understand the relationship of metric areas when they are converted to larger or smaller units of area, i.e. draw a diagram of a square metre, divide it into square centimetres to determine how many square centimetres are contained in one square metre 	<p>Materials</p> <ul style="list-style-type: none"> • BLM 4.4.1 • Metre sticks • String • Masking tape • Variety of items • Grid paper
<p>Minds On...</p>	<p>Whole Class → Discussion</p> <p>Ask students when they would and would not use cm, m and km as units of measurements. (i.e. you can start by asking them, which measurement would be most appropriate for determining the distance to your home; the distance you are from some object in the room; the length of a football field; a desk; an eraser, etc)</p> <p>Prompt the class with the questions: “how many cm are in a m” and “how many m are in a km. Record student answers on an Anchor Chart to be used for the next two lessons.</p> <p>Groups of 4 → Game</p> <p>Give each group a set of cards from BLM 4.4.1. Like the game Concentration, students will be attempting to find pairs of cards that match; except in this game the units will be different in each match (E.g. 1km matches 1000m.). To win a match, they must explain why the cards match to the rest of the group.</p>	<p>As students are playing the game, listen for how students explain the card matches</p> <p><i>Teacher Note:</i> If students are having difficulty with this section, they may need to review conversions using centimetre cubes.</p>
<p>Action!</p>	<p>Whole Class → Activity Instructions</p> <p>Explain to students that they are now going to look at converting area and reinforce that knowing how to convert lengths will help with converting area.</p> <p>Groups of 4 → Activity</p> <p>This activity can be done outside or inside. Prior to this lesson, lay out a variety of items (shoes, socks, paper cups, plates, teddy bears, receipts etc.).</p> <p>Students will take on the role of CSI detectives working on a recent crime scene. In order to conduct the investigation, they must create square metre around the actual crime scene, and mark off the perimeter of the crime scene using string. Have students break the area up into square centimetres.</p> <p>Students will use their square metre’s grid to create a scale drawing of their crime scene on a piece of grid paper; using the grid, they can place the items in the same location as the actual crime scene.</p>	<p>It may be easier for some students to have the square metre drawn out on paper to divide into cm^2.</p>
<p>Consolidate Debrief</p>	<p>Whole Class → Discussion</p> <p>Have students showcase their scale drawings and explain how they used the square metre to help them. Prompt groups with the following questions: Approximately how big was your object in cm^2? How do you know? Approximately how big is your object in m^2? Which measurement is easier to estimate?</p> <p>Prompt the class with the following questions:</p> <p>How many cm^2 are in a m^2? How is this conversion of area different from making length conversions?</p> <p>As a class, establish some type of formula for converting metric units of area.</p>	
<p>Reflection</p>	<p>Home Activity or Further Classroom Consolidation</p> <p>Written journal entry addressing the following question:</p> <p>Where would knowing how to convert metric units of area help you in your everyday life?</p>	

100 cm	1 m	10 mm	1 cm
1 km	.10 cm	1 mm	2.5 m
3.5 km	3500 m	.25 m	25 cm
7000 mm	.45 km	450 m	.03 cm
1000 m	250 cm	7 m	.3 mm

	<p>Math Learning Goals</p> <ul style="list-style-type: none"> Students will convert between metric units of area, i.e. square centimetres to square metres, etc. Students will solve everyday problems that require conversion of metric area measures 	<p>Materials</p> <ul style="list-style-type: none"> BLM 4.5.1 BLM 4.5.2 Geoboards
<p>Minds On...</p>	<p>Whole Class → Guided Activity Using a geoboard on the overhead projector, choose a composite shape to model for the class. Ask students to subdivide the composite shape into shapes for which they know the area formula. As a class, calculate the area of the shape in cm^2.</p> <p>Whole Class → Discussion Pose the following question to the class: 'How would you convert the area into m^2?' As students develop a reasonable explanation, prepare an anchor chart with their ideas. <i>Teacher Note:</i> Students may think they can simply divide by 100 to get the m^2 value. If this happens, have student suggest lengths and widths that could create a rectangle with that area. Compare that rectangle to the one you just created to show that the measurement does not make sense.</p>	<p>When students are subdividing shapes, ensure they are using appropriate shapes. Listen to be sure students know how to find the area of the different shapes. Record anecdotal notes</p>
<p>Action!</p>	<p>Individual → Investigation In this investigation, students are asked to redecorate a room. Students will choose a composite shape from BLM 4.5.1, measure the lengths of all the sides and find the area in both cm^2 and m^2. Students will determine the most suitable square tile dimensions from the choices below, and explain their thinking.</p> <p>Tile Choices: Tile A – 30 cm x 30 cm Tile B – 15 cm x 15 cm Tile C – 10 cm x 10 cm</p>	<p>Ensure students don't confuse length conversion with area conversion</p>
<p>Consolidate Debrief</p>	<p>Whole Class → Discussion Students will share with the class how they subdivided their shape, and how they converted the area into m^2. They will also give their rationale of tile choice and how they determined what tiles would fit best.</p>	<p>Help students subdivide the shape into familiar shapes (squares, rectangles) Reduce the size of the tile, or provide them with the tile size to use.</p>
<p><i>Application Concept Practice</i></p>	<p>Home Activity or Further Classroom Consolidation Practice finding the surface area of parallelogram right prism by completing worksheet 4.5.2. Describe an everyday situation where finding the surface area of a parallelogram based prism is required. Determine the dimensions. Find the surface area. Include a labelled diagram and a net.</p>	

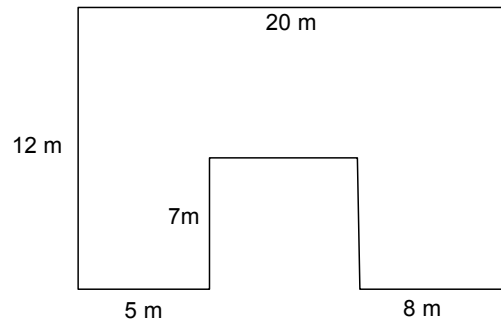
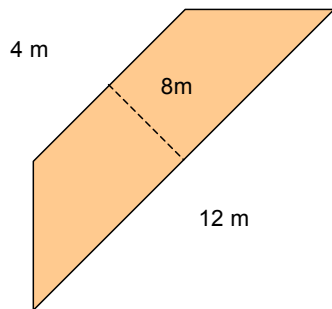
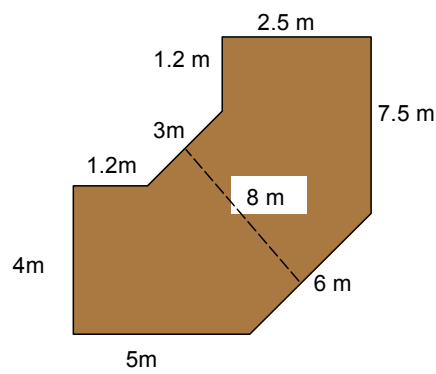
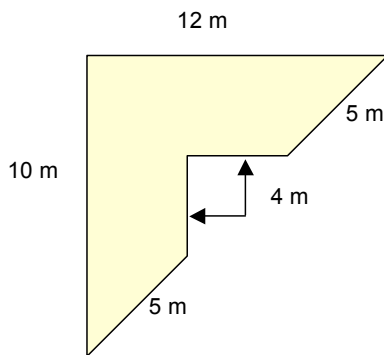
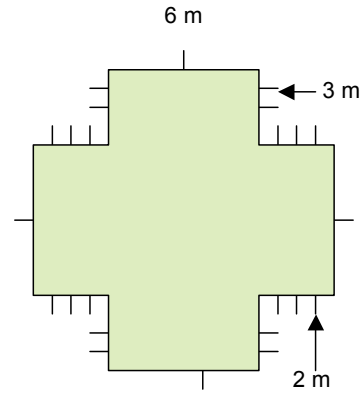
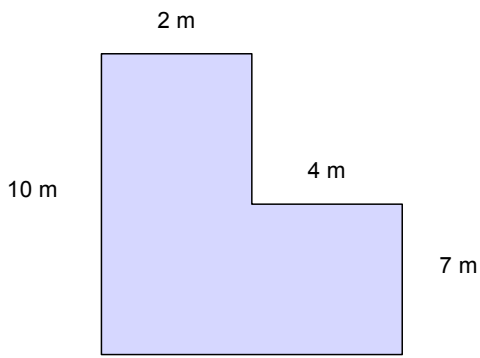

4.5.2: Application of Conversion of Metric Units of Area

Grade 7

1. Myles has a room that is 300 m^2 . If he wants to tile the room using $5 \text{ cm} \times 5 \text{ cm}$ tiles, how many whole tiles will he have to use?

2. Sam needs your help to measure his room because he only has a ruler that measures in cm. He needs to convert his measurements into metres and find the area of the room. The room measures as follows:

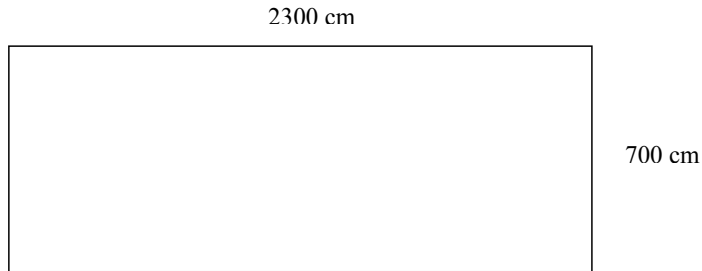

3. Myles is painting the four walls and ceiling of his bedroom. The bedroom is 600 cm long, 450 cm wide and 300 cm high. Paint come in 4 L cans. One litre of paint covers 10 m^2 . What is the area that Myles needs to paint? How many cans of paint will he need?



Math Learning Goals

- Understand the definitions and characteristics a trapezoid.
- Make a graphic organizer and/or a Venn diagram that shows different polygons, and in particular, different quadrilaterals, including trapezoids.

Materials

- BLM 4.6.1

Assessment Opportunities

Minds On...

Whole Class → Classifying 2-D Figures

Begin a graphic organizer or Venn diagram for 2-D figures. Focus on quadrilaterals that the students are familiar with (rectangles, squares, rhombi, parallelograms).

- Word Wall
- rhombi
 - parallelograms
 - trapezoids

Action!

Pairs → Investigation

Discuss the definition of *trapezoid* with the class, and draw some sketches on the board.

In pairs, students complete BLM 4.6.1.

Mathematical Process (Communicating)/Oral Questions/Anecdotal Note: Assess students' ability to read mathematical language and interpret the meaning.

Whole Group → Discussion

Ask: Is a trapezoid a 2-D shape or a 3-D figure?

Individual students respond, including a brief justification.

Students make connections by suggesting where isosceles trapezoid figures or shapes are found in the world around them, e.g., the "D connector" for the monitor on the back of the CPU.

The glossary of *The Ontario Curriculum, Mathematics, Revised, Grades 1–8* defines *trapezoid* as "a quadrilateral with one pair of parallel sides." Diagrams for isosceles and right trapezoids can be found there.

Consolidate Debrief

Whole Class → Sharing

Different students explain their reasoning to questions 1–4 (BLM 4.6.1). They draw diagrams on the overhead or board to illustrate their reasoning.

Discuss where *trapezoid* should be placed on the graphic organizer/Venn diagram.

Concept Practice Reflection

Home Activity or Further Classroom Consolidation

Identify which of the shapes on worksheets 4.2.1 and 4.2.2 are trapezoids. Explain how you could find the areas of these trapezoids. Summarize this into a written strategy or into a formula.

4.6.1: What Is a Trapezoid?

The definition that most North American mathematicians use for *trapezoid* is “a four-sided shape with exactly one pair of opposite sides parallel.”

An isosceles trapezoid is one whose non-parallel sides are equal.

1. Could an isosceles trapezoid be a parallelogram? Explain.
2. Can the parallel sides of an isosceles trapezoid be equal? Explain.
3. Can the parallel sides of any trapezoid be equal? Explain.
4. Can a trapezoid ever have:

- | | | |
|---------------------------------|-----|----|
| i) no right angles? | Yes | No |
| ii) only one right angle? | Yes | No |
| iii) exactly two right angles? | Yes | No |
| iv) exactly three right angles? | Yes | No |
| v) exactly four right angles? | Yes | No |

Explain your reasoning or draw a labelled diagram to justify your answer to each question above.

**Math Learning Goals**

- Investigate ways to determine the area of a trapezoid.
- Develop strategies for finding the area of a trapezoid.

Materials

- BLM 4.7.1

Minds On...**Pairs → Think/Pair/Share**

Give students two minutes to think about and record independently the process that they would use to determine a strategy for finding the area of a trapezoid. Students share ideas with a partner. Using a different colour, students record any changes they wish to make in their process.

Assessment Opportunities

This activity leads directly into further investigation of trapezoids.

Action!**Individual → Investigation**

Students work through BLM 4.7.1, using manipulatives and materials, as appropriate. They state a strategy to find the area of a trapezoid and provide justification for their conjecture.

It is more important that students use the inquiry process than that they generate the usual form for the rule or formula.

Mathematical Process/Reasoning and Proving/Demonstration/Mental Note: Assess students' ability make and justify conjectures.

**Consolidate
Debrief****Whole Class → Sharing**

Students discuss the processes they used and the strategies that they discovered for finding the area of a trapezoid. Compare the strategies, and discuss the relative merits of each.

Home Activity or Further Classroom Consolidation

Identify as many trapezoids as possible in your home, school, and community.

*Concept Practice
Reflection*

4.7.1: Area of a Trapezoid

Name:

Date:

Your company has been hired to seal paved highways. Sealant is applied in trapezoidal sections to ensure bonding. As there are curves and intersections, the trapezoids change size and shape for each area. Engineers need to determine the amount of sealant required to cover any trapezoidal area.

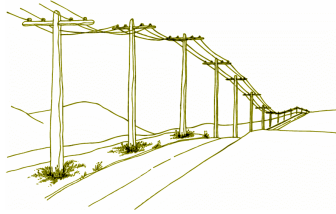

Trapezoids are four-sided polygons with two parallel sides. Some examples are provided:

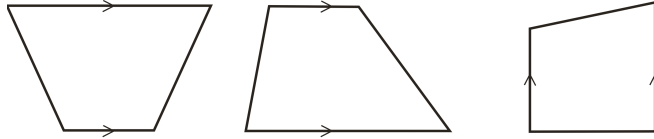

Task

Determine a rule the engineers could use to calculate the area of any trapezoid.

Suggested methods include:

- Use pattern blocks to construct various trapezoids and then sketch them on dot paper.
- Draw several trapezoids on dot paper, determine their areas, and look for a pattern.
- Construct a variety of trapezoids and take useful measurements for calculating the area.
- Cut out the trapezoids and cut them further into basic shapes, like squares, rectangles, and triangles.

Record any numerical data that may help you identify patterns in an organized fashion.

Describe how to find the area for any trapezoids. Express your rule as clearly as possible, using words, pictures, and symbols.



Math Learning Goals

- Construct points, segments, parallel lines, and shapes using The Geometer's Sketchpad® 4
- Practise constructing and measuring trapezoids using The Geometer's Sketchpad® 4.

Materials

- GSP® 4
- BLM 4.8.1

Assessment Opportunities

Minds On...

Small Group → Brainstorm

Generate a list of trapezoids that students discovered in the previous day's Home Activity.

Ask: What are the similarities and differences between using a computer to explore geometry and measurement, and pencil-and-paper work?

Students work in groups to design a Venn diagram to show relationships.

Groups share their brainstorming ideas with the entire class.

Action!

Pairs → Guided Exploration

Guide students as they explore various functions of The Geometer's Sketchpad® 4 (BLM 4.8.1).

Students take turns, with one student focusing on the instructions and the other using the program.

Students save their trapezoids for Day 11.

Learning Skills/Observation/Anecdotal Note: Observe students' ability to work independently and cooperatively throughout the activity.

Use a data projector to demonstrate GSP® 4 to facilitate students learning how to use the program.

Consolidate Debrief

Whole Class → Sharing

Lead a discussion based on the students' experience with The Geometer's Sketchpad® 4.

- How did using The Geometer's Sketchpad® 4 help you develop your understanding of trapezoids and/or computers?
- What challenges did the program present for you?
- What would you like to learn more about?
- For what kinds of applications do you think a program like this could be useful?
- Explain your answers to questions 30 and 31 (BLM 4.8.1).
- How could you use The Geometer's Sketchpad® 4 to construct a parallelogram that would stay a parallelogram when its points are dragged?

Home Activity or Further Classroom Consolidation

Answer the questions in your math journals:

- How does GSP® 4 help me to understand geometry better?
- What would I like to explore further, using GSP® 4?
- How could this program be useful to me?

Reflection

4.8.1: Introduction to The Geometer's Sketchpad® 4 Using Trapezoids

Name:

Date:

Getting Started

1. Launch The Geometer's Sketchpad®4.
2. Click the mouse anywhere to close the introductory window.
3. Maximize both of the geometry windows.
4. Notice the six tools at the left of the working area. The second one down is the **Point Tool**. Click on it, and then click in four different places in the work area to make four points.
5. The fourth tool down is the **Segment Tool**. Click on it, and then connect the four points with segments to form a quadrilateral.
6. The first tool is the **Selection Arrow Tool**. Click on it, and then drag the points and segments to move them around. Try to make your quadrilateral look like a trapezoid.

Follow the directions below to construct a new trapezoid. Once created, the parallel sides of the trapezoid will remain parallel regardless of how you drag the points or segments.

Constructing a Real Trapezoid

7. Select **New Sketch** from the File menu.
8. Construct two points and the segment between them.
9. Construct a third point not on the segment.
10. Using the **Selection Arrow Tool**, select the segment and the third point by clicking on them. They are highlighted in pink. The original two points should not be selected.
11. From the **Construct** menu, select **Parallel Line**. You now have a line constructed and automatically selected.
12. From the **Construct** menu, select **Point on Parallel Line**. This creates a highlighted point, which is forced to always stay on the parallel line.
13. Click the background to deselect the new point.
14. Select only the newly constructed parallel line and select **Hide Parallel Line** from the **Display** menu.
15. Use the **Selection Arrow Tool** to drag the new point around. Notice that you can't drag it off the hidden line.
16. Construct three more segments to finish the trapezoid.
17. Use the **Selection Arrow Tool** to drag the vertices (points) and segments of the trapezoid. Note that however you drag each point or segment, the two parallel lines always stay parallel.
18. Drag points and/or segments to make your trapezoid look like:
 - a) an isosceles trapezoid
 - b) a parallelogram
 - c) a rectangle
 - d) a rectangle joined to a right triangle

4.8.1: Introduction to The Geometer's Sketchpad® 4

Using Trapezoids (continued)

Measuring Your Trapezoid

19. Use the trapezoid you created earlier in this investigation.
20. Click the background to de-select everything.
21. Using the **Selection Arrow Tool**, select the four points of your trapezoid in a clockwise or counter-clockwise direction.
22. From the **Construct** menu, select **Quadrilateral Interior**. Notice that the inside of the trapezoid becomes coloured and shaded.
23. From the **Measure** menu, select **Perimeter**. Notice that the perimeter is shown in the upper-left corner of the working area.
24. From the **Edit** menu, select **Preferences**. On the **Units** tab, set the **Distance Units** to **cm** and all **Precision** levels to **tenths**. Click **OK**.
25. Drag the points of the trapezoid to adjust its perimeter to:
 - a) 25.0 cm.
 - b) 40.0 cm.
26. Click the background to de-select everything. Click inside the trapezoid to select it.
27. From the **Measure** menu, select **Area**.
28. Drag the points of the trapezoid to adjust its area to:
 - a) 25.0 cm².
 - b) 40.0 cm².
29. Can you create a trapezoid with a:
 - a) perimeter of 25.0 cm and an area of 40.0 cm²?
 - b) perimeter of 40.0 cm and an area of 25.0 cm²?
30. When you drag one of the first three points that you originally created, another point always gets dragged along with it. Explain why this happens.

31. When you drag the fourth point, it moves by itself. Explain why it acts differently than the other points.

**Math Learning Goals**

- Understand that a trapezoid can have zero or two right angles.
- Develop the formula for the area of a trapezoid containing two right angles.

Materials

- centimetre grid
- paper
- BLM 4.9.1

Assessment Opportunities**Minds On...** **Whole Class → Guided Discussion and Reading**

Conduct a brief discussion about types of taxes, e.g., property taxes, GST, PST, income tax.

Prompt students' thinking as they read the scenario text on BLM 4.9.1:

- How can you recognize a right angle in a 2-D shape?
- Why did the mathematicians reshape their lots?
- What were the shapes of the lots before and after the tax?
- How many right angles did each lot have?
- Why did the mathematicians want to keep the areas of their lots unchanged?
- Do you think the mathematicians were justified in changing the shapes of their lots? Explain why or why not.

Action!**Pairs → Solving Problems**

Students complete questions 1 and 2 (BLM 4.9.1). They explain any relationship they found between the length of a lot before the tax and the sum of the lengths of the parallel sides after tax.

Prompt them to explain how to use this relationship to calculate the area of a trapezoid, containing two right angles.

Individual → Investigation

Students complete questions 3 and 4 (BLM 4.9.1). Students should discover that a line segment drawn through the midpoint of the boundary between A and B divides it into two trapezoids with the same areas as rectangles A and B.

Help students who experience difficulty by suggesting that they fold their rectangle in half along a line parallel to its length. The point where the fold intersects the boundary between rectangles A and B is the point through which any line segment joining opposite sides can be drawn to yield the desired result.

Curriculum Expectations/Demonstration/Checkbric: Assess students' ability to investigate area relationships and calculate and apply to trapezoids.

Consolidate Debrief**Whole Class → Discussion of Findings**

Facilitate student discussions of their findings for questions 3 and 4, emphasizing that there are many ways to transform a rectangle into a trapezoid of the same area. Point out that trapezoids can have either zero or two right angles.

Home Activity or Further Classroom Consolidation

In your math journal, explain how to find the area of any right-angled trapezoid. Include an example.

Develop a formula for the area of a right-angled trapezoid given the lengths of its parallel sides and the distance between them.

*Exploration
Reflection*

4.9.1: The Mathematicians Transform Rectangles into Trapezoids

(Impact Math – Measurement, Activity 2)

Gulliver observed, with some contempt that the mathematicians seemed to avoid practical matters. They built their homes without right angles and located their houses on odd-shaped lots. Gulliver was apparently unaware of the reasons why the mathematicians constructed their buildings (and their lots) in unsymmetrical shapes. Legend tells how the king, in his attempt to raise more revenue from his people, levied a special tax on any lot that contained more than two right angles. Two mathematicians, Alpha and Beta, with adjoining rectangular lots, reshaped their lots as shown, to avoid this special tax.

Gulliver proclaimed:

“These mathematicians are under continual stress, never enjoying a minute’s peace of mind, for they are always working on some problem that is of no interest or use to the rest of us. Their houses are very ill built, the walls bevel, without one right angle in any apartment; and this defect ariseth from the contempt they bear for practical geometry. They despise it as vulgar and impure...Although they can use mathematical tools like ruler, compasses, pencil, and paper, they are clumsy and awkward in the common actions and behaviours of life.”



By reconstructing their lots as shown above, the mathematicians Alpha and Beta changed each rectangular lot into a *trapezoid*.

1. a) The diagram below shows two trapezoids. Write a sentence to define a trapezoid.
Check your definition with a dictionary.
b) How many right angles are there on each trapezoid shown here?
Do all trapezoids have the same number of right angles? Explain.
c) Did Alpha and Beta have to pay the special tax on their new lots? Explain.

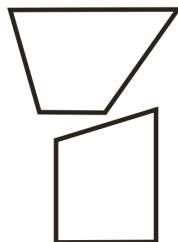

4.9.1: The Mathematicians Transform Rectangles into Trapezoids (continued)

2. a) Measure the length and width in millimetres of Alpha's and Beta's lots **before** the special tax was imposed. Record in the table on the left.

Before Tax			
	Length	Width	Area
Alpha			
Beta			

After Tax			
	Sum of the Lengths of the Parallel Sides	Distance Between the Parallel Sides	Area
Alpha			
Beta			

- b) Trace and cut out both lots as they were after the special tax. Place your cutouts on centimetre paper to determine the area of each lot and the lengths of the parallel sides. Record in the table on the right.
- c) Did Alpha and Beta change the areas of the lots when they reshaped them? Explain.
- d) Compare the length of Alpha's rectangular lot to the sum of the lengths of the parallel sides of Alpha's trapezoidal lot. Repeat for Beta's lot. Describe what you discover.
- e) Explain how to calculate the area of a trapezoid containing a right angle, given the lengths of its parallel sides and distance between them.
3. a) Draw two rectangles of length 9 cm and width 6 cm on centimetre paper. Divide one of the rectangles into two rectangles A and B with dimensions 5 cm × 6 cm and 4 cm × 6 cm.
- b) Use what you learned in Exercise 2 to divide the other rectangle into trapezoids C and D so the areas of A and C are the same and the areas of B and D are the same. Explain how you did this. How many ways do you think this can be done?



4. a) Draw a 12.5 cm × 6.5 cm rectangle on a sheet of paper. Divide your rectangle into two other rectangles X and Y and record their areas. Cut out your rectangle and divide it into two trapezoids so that one has the same area as X and the other the same area as Y.
- b) Measure the dimensions of each trapezoid and calculate its area as in 2b. Record the areas of the trapezoids and verify that they are equal to the areas of X and Y.

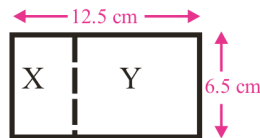



Math Learning Goals

- Develop a formula to calculate the area of any trapezoid.

Materials

- BLM 4.10.1, 4.10.2, 4.10.3

Assessment Opportunities

Minds On...

Whole Class → Shared Reading

Read aloud the story and poem on BLM 4.10.1, Part 1. Discuss the questions using the following prompts:

- Mathematically, what is the meaning for *mean*?
- Why does the tax appraiser use the “mean parallel side”?
- For which other figures is area calculated using base and height?

Make connections to measures of central tendency: mean, median, mode (especially *mean*.)

Action!

Pairs → Exploration

Option 1

Pairs work through BLM 4.10.2, Part 2.

Option 2

Students use their trapezoid file for The Geometer’s Sketchpad®4 from Day 9 as they work through BLM 4.10.3.

Curriculum Expectations/Application/Mental Note: Assess students’ understanding of how to calculate the area of a trapezoid.



Consolidate Debrief

Whole Class → Reflection

Facilitate discussion as students reflect on the day’s activities.

Students share formulas. Stress similarities and develop a common formula. Reach a consensus that the formula for the area of a trapezoid could be the average (mean) of the lengths of the two parallel sides times the distance between them.

Note: Formulas may look different but are actually equivalent. Application of understanding of number sense, algebra, and order of operations can be used to confirm equivalence of formulas that appear to be different.

Exploration

Home Activity or Further Classroom Consolidation

- Explain to someone one or two strategies for remembering the formula for the area of a trapezoid. Record any questions or discussion items raised during your conversation.

OR

- Find two different trapezoids in your surroundings. Measure the lengths of the parallel sides and the distance between them. Make a sketch, include the dimensions you found, and find the area of each.

4.10.1: The King Moves from Angles to Area (Part 1)

(Impact Math – Measurement, Activity 3)

... the king levied a special tax on lots with more than two right angles. In response, the mathematicians reshaped their rectangular lots into trapezoids of the same area. In this way they preserved the size of each lot and escaped the new tax. The king was not amused, and sent his tax appraiser to announce new tax measures.

The king is quite clearly annoyed,
For the taxes you tried to avoid.
By changing your lots
From rectangular plots,
To cleverly-shaped trapezoids.

So the king ordered me to advise
That he will tax each lot by its size;
For he doesn't care
Trapezoid or square,
The area only applies.

Your tax appraiser's no fool,
He calculates fast without tools.
Mean parallel side
Times measurement wide
Is his trapezoid area rule.

1. How did the king revise the special tax provision so that taxes would not depend on the shape of the lot?
2. What does the tax appraiser mean by “mean parallel side”? By “measurement wide”?
3. Describe in your own words how the tax appraiser calculates the area of a trapezoid.
4. Write as a formula the tax appraiser’s rule for calculating the area of a trapezoid that has parallel sides of length a and b if the distance between these sides is d units. Do you think this formula works for a trapezoid that has no right angles? Give a reason for your answer.

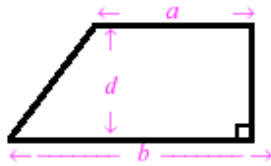

4.10.2: The King Moves from Angles to Area (Part 2)

(Impact Math – Measurement, Activity 3)

- Is the tax appraiser's rule for calculating the area of a trapezoid the same as the formula you discovered in Activity 2 (BLM 4.9.1)? Explain your answer.
 - Use the tax appraiser's rule to calculate the areas of the trapezoids drawn on this centimetre grid.

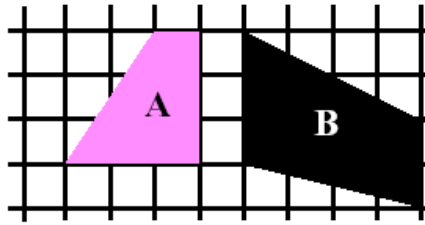

- Draw a line segment to divide trapezoid A in Exercise 1 into a right triangle and a rectangle. Calculate the areas of the rectangle and triangle to find the area of trapezoid A. Compare with your answer in 1b.
 - Divide trapezoid B in Exercise 1 into two triangles. Then use the formula for the area of a triangle to calculate the area of trapezoid B. Compare with your answer in Exercise 1b.

- Draw a trapezoid like the one on the right on centimetre paper and count squares to determine its area. Draw another trapezoid congruent to it. Cut out both trapezoids and fit them together to form a rectangle.
 - Record the area of the rectangle and the area of each trapezoid in 3a.
 - A congruent copy of the trapezoid below is made and they are fitted together to form a rectangle as shown.

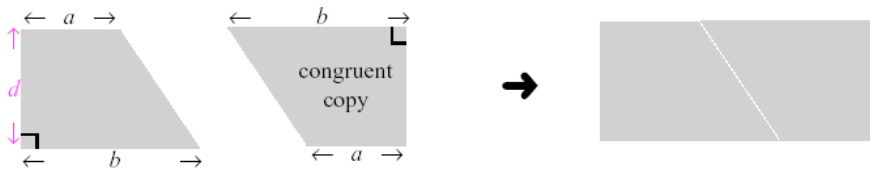
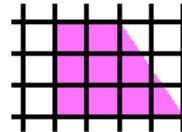

Write an expression for the area of the rectangle and for the area of each trapezoid in terms of a , b , and d .

- A congruent copy of the trapezoid below is made and they are fitted together to form a parallelogram as shown.

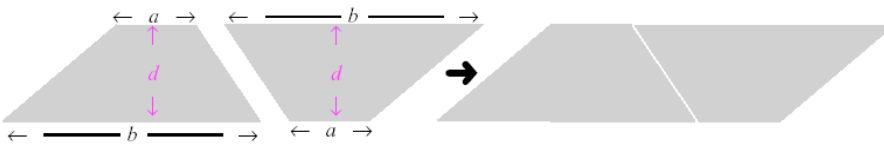

Challenge

Write an expression for the area of the parallelogram and for the area of the trapezoid in terms of a , b , and d . Show your work.

4.10.3: Developing a Formula for the Area of Trapezoids Using The Geometer's Sketchpad® 4

Name:

Date:

What Do Two Trapezoids Make?

1. Launch The Geometer's Sketchpad® 4.
 2. Open the file containing the trapezoid you created in Day 9 of this unit.
 3. Select any side of the trapezoid. From the **Display** menu, choose **Color** and pick a colour for that side. De-select the side. Colour each of the other three sides of the trapezoid differently.
 4. Select one of the non-parallel sides of the trapezoid. From the **Construct** menu, choose **Midpoint**.
 5. With this midpoint selected, choose **Mark Center** from the **Transform** menu (or simply double-click on the midpoint).
 6. Use **Select All** from the **Edit** menu. Choose **Rotate** from the **Transform** menu. The angle to rotate the trapezoid is 180° .
 7. You have now constructed an exact, congruent copy of the trapezoid. By matching colours, notice to which position each of the original segments was rotated.
 8. What type is the resulting shape?
Test your answer by dragging various points and noting if the type of shape remains the same or changes to a different type.
 9. Select all of the vertices (corner points) of the original trapezoid. From the **Construct** menu, choose **Quadrilateral Interior**. Use the **Measure** menu to find its area.
 10. Repeat step 9 to find the area of the entire figure.
 11. What is the relationship between these two areas? Why does this make sense?
12. Label the two parallel sides b_1 and b_2 . Write a formula for the area of the whole shape, in terms of h , b_1 and b_2 , where h is the distance between the two parallel sides.
13. Using information from 11 and 12 above, write a formula for the area of the original trapezoid, in terms of h , b_1 and b_2 .

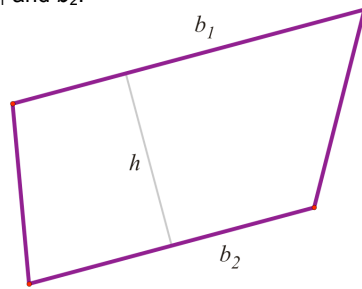



Math Learning Goals

- Solve problems involving the perimeter and area of trapezoids.

Materials

- BLM 4.11.1, 4.11.2

Assessment Opportunities



Minds On... Whole Class → Sharing

Student volunteers share their journal entries from the previous day. Students answer some of the questions posed during the conversation. Briefly review concepts discussed on BLM 4.11.1, Part 1.



Action! Individual → Applying Knowledge

Students complete questions 1, 2, and 3, including the report, on BLM 4.11.1, Part 2. Students complete BLM 4.11.2. Circulate to ensure students stay on task, and to clarify task requirements.

Curriculum Expectations/Application/Rating Scale: Assess students' understanding of how to calculate the area of a trapezoid.



Consolidate Debrief Whole Class → Sharing

- Ask:
- What did you find difficult?
 - What was straightforward?
 - How can you improve upon what you did today?

Exploration

Home Activity or Further Classroom Consolidation

Record places in your home environment where trapezoids are found. Answer the following questions in your math journal:

- Where do you find trapezoids in your home?
- Why are trapezoids in common use?

Example of trapezoids: tiles near the edge of angled walls or the area between the rungs of a kitchen chair or other furniture with splayed legs.

4.11.1: Is It Mathematics or Magic? (Part 1)

(Impact Math – Measurement, Activity 4)

We learned in Activity 3 that the tax appraiser in Laputa was very good at calculating areas. He was particularly proud of his rules for calculating the areas of triangles and trapezoids.

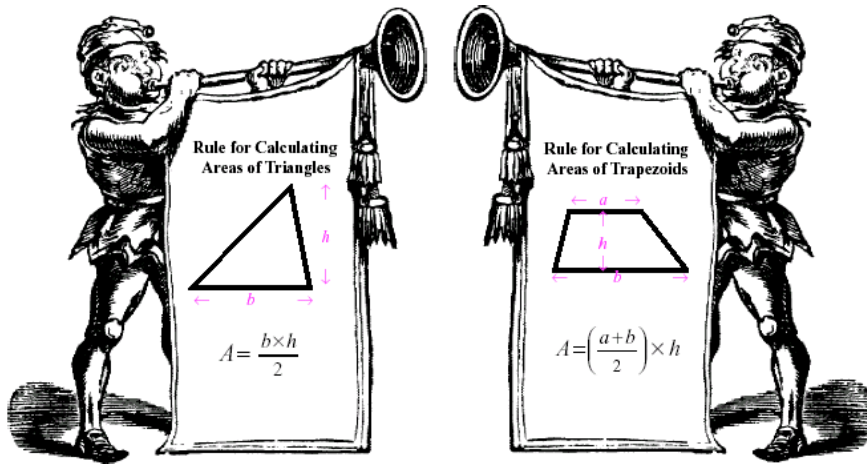

Knowing the tax appraiser's eagerness to apply these rules, the mathematicians Alpha, Beta, Gamma, and Delta constructed their lots as shown here. Each centimetre on the grid stands for a Laputian distance unit.

The tax appraiser recorded the dimensions of each lot in tables like these.

Triangles			
	Base	Height	Area
Beta			
Gamma			

After Tax			
	Lengths of Parallel Sides	Distance Between Parallel Sides	Area in Square Units
Alpha			
Delta			

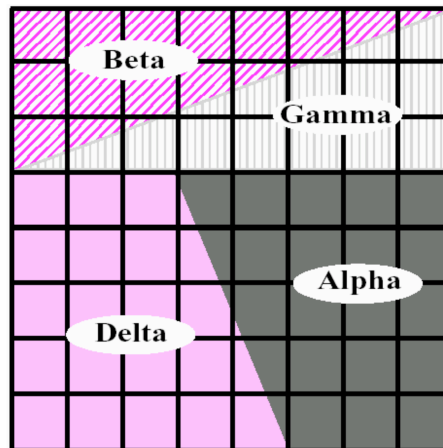

4.11.1: Is It Mathematics or Magic? (Part 2)

(Impact Math – Measurement)

ACTIVITY 4 – STUDENT PAGE

- 1 a) Complete the tables on the other page, recording each centimetre as a Laputian unit.
 - b) What do you notice about the areas of triangles Beta and Gamma?
 - c) Are Beta and Gamma congruent triangles? Explain why or why not.
 - d) Are trapezoids Alpha and Delta congruent? Explain why or why not.
 - e) Add the areas in your table to find the total area of all four lots.

After the tax appraiser computed the areas of the four lots, the mathematicians rearranged their lots on the building plans as shown below.

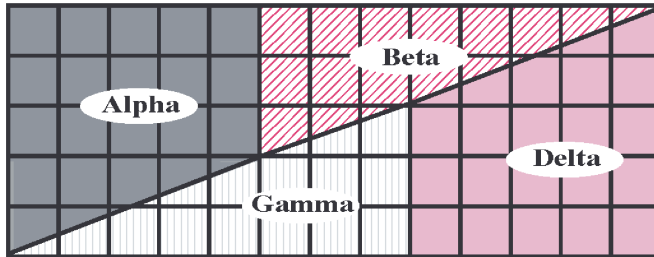

- 2 a) What is the total area of this rectangle?
 - b) Compare your answers in 1 e and 2 a and explain why the tax appraiser became confused.
- 3 a) Using centimetre paper, cut out lots Alpha, Beta, Gamma, and Delta with the dimensions given in your tables. Show they have a total area of 64 cm^2 by arranging them in an $8 \text{ cm} \times 8 \text{ cm}$ square.
 - b) Arrange these lots in a rectangle of length 13 cm and width 5 cm . What is the total area of the lots? Where did the extra unit of area come from?

REPORT

Write a letter on a scroll to the king indicating whether the total area taxed should be 64 square units or 65 square units. Give reasons to support your argument.

Indicate what percent of the total tax should be assigned to each of the four lots.

Research:

How is land taxed in your municipality?
By area? By frontage?
By market value?

CHALLENGE

TAX APPRAISER'S LIMERICK

*The trapezoid rule 'tis true,
Applies to other shapes too.
Triangle's trapezoid
With one side that's void,
And parallelogram follows the rule.*

The tax appraiser's limerick suggests that the formula for the area of a trapezoid applies to triangles and parallelograms. Explain what is meant by "one side that's void." Show how the formula for the area of a trapezoid becomes a) $b \times h/2$ as side length a gets close to 0 .
b) $b \times h$ when $a = b$.

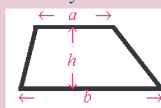

4.11.2: Application of Trapezoid Area and Perimeter

Name:

Date:

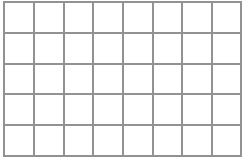
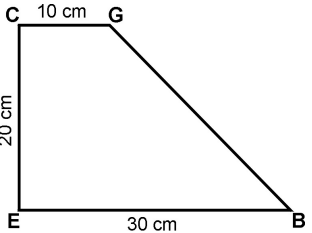
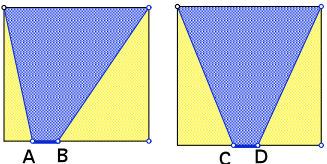
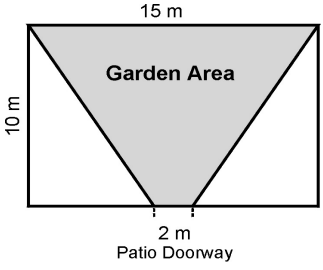
<p>1. Problem Solving, Reflecting</p> <p>Alpha was planning to fence in his pet monkey's play area. He has 16 m of fencing and the area of his <u>trapezoidal</u> area is 12 m^2. Draw the shape of the <u>trapezoidal</u> monkey play area. Include all necessary dimensions.</p>  <p>Scale: one grid unit = 1 m</p> <p>Hint: $A = \frac{(a + b)h}{2}$</p>	<p>2. Reasoning and Proving</p> <p>In order to please the king, Beta baked a cake for him. The king would like to share the cake equally with the queen. Show where he should make the cut(s). Justify your answer.</p> 
<p>3. Problem Solving, Reasoning and Proving</p> <p>Gamma has been hired to make ceramic floor tiles for the queen's palace. Note: The square tiles that are shown are the same size. AB and CD have the <u>same</u> length. How can Gamma use the formula for the area of a trapezoid to convince the queen that the inside dark areas are the same size?</p>  <p>Hint: $A = \frac{(a + b)h}{2}$</p>	<p>4. Connecting</p> <p>Delta's backyard is rectangular. Its dimensions are 15.0 m by 10.0 m. Delta's family is making a garden from the patio doors to the corners at the back of the yard. The patio doors are 2.0 m wide. Determine the area of the garden. Show your work.</p> 



Math Learning Goals

- Investigate to determine the characteristics of right prisms.
- Identify and build a variety of right prisms, e.g., with bases that are squares, rectangles, triangles, parallelograms, and trapezoids.

Materials

- Right prisms
- Frayer charts
- BLM 4.12.1, 4.12.2, 4.12.3, 4.12.4

Assessment Opportunities

Minds On...

Whole Class/Groups → Vocabulary Development

Show students a collection of familiar items that are right prisms – cube, rectangular prisms, triangular-based prism chocolate bar box, octagonal-based box, cylindrical container. Students name and describe the solids, using appropriate mathematical vocabulary. See BLM 4.12.3 (Teacher).

Students create definition Frayer charts for some or all of the words used to describe right prisms. (*Key terms: prism, vertices, edges, faces, etc.*). Students share their charts orally with the class and post them on the Word Wall. Students may need help drawing 3-D figures. See BLM 4.12.4.

Word Wall
 • cube
 • rectangular prism
 • triangular prism
 • pentagonal prism
 • hexagonal prism
 • octagonal prism
 • trapezoidal-based prism
 • parallelogram-based prism

See 5.1.1 for Frayer Model Template

See *Think Literacy: Cross Curricular Approaches – Mathematics*, p. 22–39.

The nets on BLM 4.12.3 can be enlarged.

Keep these prisms for other activities that will be completed during the unit.

Instructions for constructing a pentagon using GSP® 4 can be found in Unit 8, Day 5, BLM 8.5.1. This same method can be used to construct any regular polygon.

Make available polydron materials to assist students in doing the activity.

Action!

Pairs → Making Models

Each pair of students creates one right prism, using polydron materials or nets.

Ensure that at least one of each type of prism is constructed for this investigation: cube, rectangular prism, triangular prism, pentagonal prism, hexagonal prism, octagonal prism, trapezoidal-based prism, parallelogram-based prism.

Pairs → Investigation

Students investigate the characteristics of the faces, edges, and angles of right prisms. Students examine their prism and fill in the appropriate row of the chart (BLM 4.12.1). When all students have completed the row for their right prism, use a chain from pair to pair, to circulate the prisms to different pairs. A student near the end of the chain walks the prism to the other end of the chain. Stop the rotation of prisms once each pair has completed the chart.

Students analyse the information gathered on their charts and note the patterns that they see. Make a list of the characteristics of right prisms.

Learning Skills/(Cooperation)/Observation/Checkbric: Observe students' ability as they work cooperatively in pairs and with the class through the investigation.

Consolidate Debrief

Whole Class → Reflecting

As students present their findings, emphasize these characteristics of right prisms:

- all the lateral faces are rectangular
- the angle between the lateral faces and the base is always 90°
- the number of edges on the prism base equals the number of lateral faces
- the angles found at the vertices of the polygon base are the same as the angles between the lateral faces.

Home Activity or Further Classroom Consolidation

How many different nets can be made for a cube? Use 6 congruent squares to investigate different nets. Sketch each net in your journal.

Bring an empty box to next day's math class.

Exploration

4.12.2: Assessment Tool

Learning Skills	Needs Improvement	Satisfactory	Good	Excellent
Independent Work				
• works on task without supervision				
• persists with tasks				
Initiative				
• responds to challenges				
• demonstrates positive attitude towards learning				
• develops original ideas and innovative procedures				
• seeks assistance when necessary				
Use of Information				
• asks questions to clarify meaning and ensure understanding				

4.12.3: Right Prisms and Their Nets (Teacher)

A right prism is a prism with two congruent polygon faces that lie directly above each other. The base is the face that “stacks” to create the prism. This face determines the name of the prism.

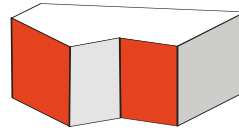

Some right prisms and their nets:

<p>Triangular prism:</p>	<p>Square prism (cube):</p>
<p>Rectangular prism:</p>	<p>Pentagon-based prism:</p>
<p>Hexagon-based prism:</p>	<p>Octagon-based prism:</p>
<p>Trapezoid-based prism:</p>	<p>Parallelogram-based prism:</p>
<p>Right prisms with bases that are composite figures:</p> <div style="display: flex; justify-content: space-around; align-items: flex-start;"> <div style="text-align: center;"> <p>Composite figure</p> </div> <div style="text-align: center;"> <p>Right prism</p> </div> <div style="text-align: center;"> <p>Composite figure</p> </div> <div style="text-align: center;"> <p>Right prism</p> </div> </div>	

4.12.4: Drawing 3-D Solids (Teacher)

Rectangular Prism

Step 1: Draw two congruent rectangles.

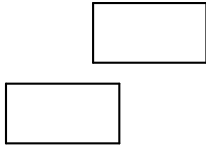

Step 2: Join corresponding vertices.

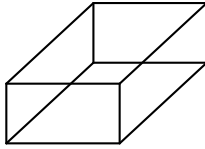

Step 3: Consider using broken lines for edges that can't be seen.

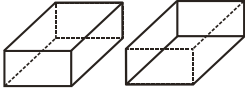

Triangular Prism

Step 1: Draw two congruent triangles.

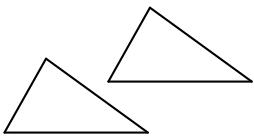

Step 2: Join corresponding vertices.

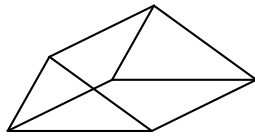

Example 1

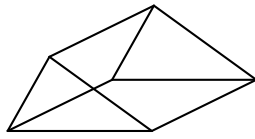
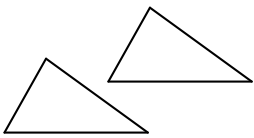

Example 2

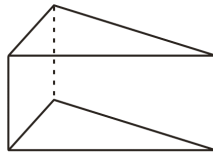
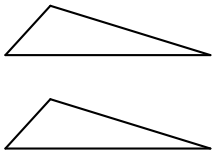

Example 3

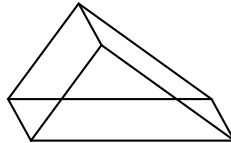
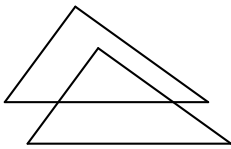



Math Learning Goals

- Develop a method for finding the surface area of a rectangular prism.

Materials

- dot paper
- boxes

Minds On...

Whole Class → Sharing

Students share their solutions for different nets of a cube, sketching possible nets on the board. Ask: Is there always more than one way to create a net for a solid? To introduce surface area, use one of the nets. Students identify and explain the connection between the area of the net and the surface area of the cube. Connect to composite shapes done earlier in the unit. Develop a definition for surface area and describe how it is the same and different from area. Discuss when it would be useful to determine the surface area of a rectangular prism.

Pairs → Investigation

Students determine a method for finding the surface area of a cube with width, length, and height 10 cm.

Whole Class → Sharing

Students share their solutions, identify which units are used, and how to properly include that information. They can represent the relationship in a variety of ways, e.g., words, variables, and numbers.

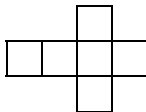

All forms are equally acceptable.
 Area of One Face, $A = l \times w$
 Total Surface Area = $A \times 6$

Action!

Small Groups → Investigation

Students use a rectangular prism (not a cube) from the group's collection of boxes, measure its sides, and use dot paper to draw a net. They calculate the surface area of the box. Encourage students to use a variety of nets and methods. Students use their solutions for calculating surface area to develop a general method for finding the surface area of a rectangular prism and record it.

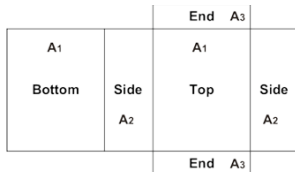

$SA = 2(A_1) + 2(A_2) + 2(A_3)$ or
 Area of each section = $l \times w$
 Surface Area =
 top + bottom + 2 sides + 2 ends
 (descriptive formula)

Learning Skills/(Cooperation)/Observation/Checkbric: Observe students' ability to work cooperatively in pairs and with the class through the investigation.

Consolidate Debrief

Whole Class → Student Presentation

Students present their methods. To assist students as they move towards symbolic representation, discuss how the various representations convey the same information or result in the same answer. Highlight advantages and disadvantages of symbolic representation.

Home Activity or Further Classroom Consolidation

Complete the practice questions.
 Sketch and label nets and calculate surface area.

Concept Practice

Assessment Opportunities

The file GSP®4 [PrismNets.gsp](#) contains adjustable nets for rectangular and triangular prisms.

This is a review from earlier grades.

Encourage students to use descriptive formulas until they are ready for symbolism.

Encourage multiple approaches for finding total surface area.

Some students may benefit visually and kinaesthetically by cutting apart the boxes to reveal the nets. Be sure to omit overlapping sections.

Some students may need to scaffold their solutions, e.g., SA of top and bottom = $2(b_1)(h_1)$
 SA of two ends = $2(b_2)(h_2)$
 SA of two sides = $2(b_3)(h_3)$
 Total SA of rectangular prism =
 $\frac{\quad}{\quad} + \frac{\quad}{\quad} + \frac{\quad}{\quad}$
 = $\frac{\quad}{\quad}$ units²

Note: "b" and "h" vary depending on which rectangular side is being considered.

Include questions that require conversion between metric units of area.

Prism Nets (GSP®4 file)

[PrismNets.gsp](#)

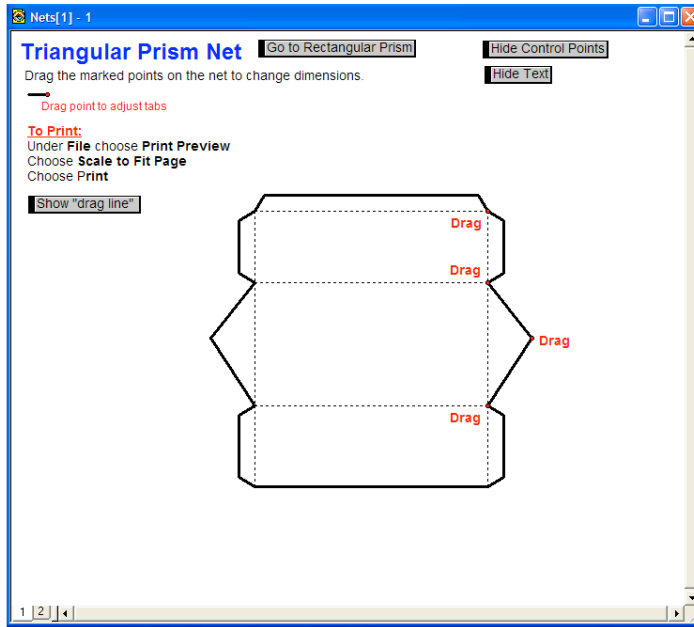
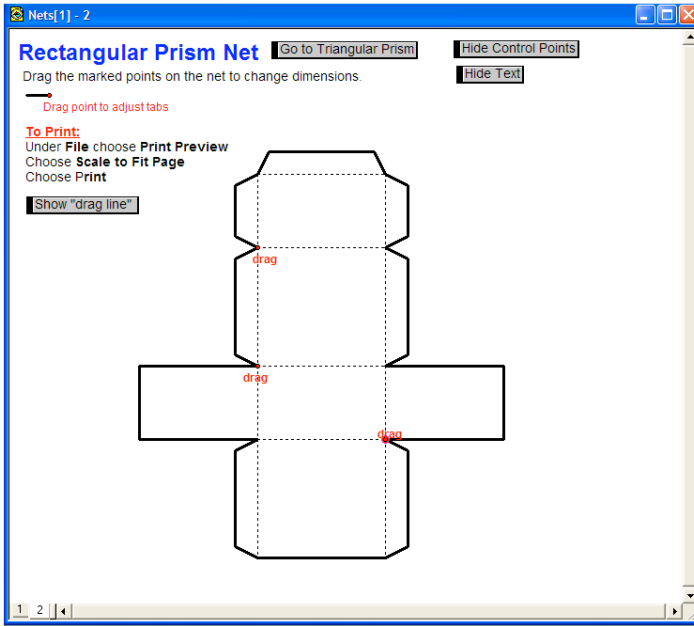

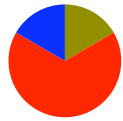

Math Learning Goals

- Develop a method for finding the surface area of a triangular prism.
- Solve problems involving the surface area of triangular prisms.
- Solve problems that require conversion between metric units of area.

Materials

- BLM 4.14.1, 4.14.2
- polydrons
- calculators

Assessment Opportunities

Minds On...

Small Groups → Sharing

Students discuss the homework problem that was the most challenging for them, comparing solutions and methods used.

Pairs → Investigation

Students draw a large (full page) triangle in their journal. Students measure the base and height of their triangle and determine its area, using a calculator. To reinforce the concept that there are three base and height pairs for a triangle, they calculate the area two other ways (e.g., use cm for two ways and mm the third way) and compare answers.

Students should represent their method using words, variables, or numbers.

Action!

Small Groups → Conferencing

Students make a right prism with a scalene triangle base (BLM 4.14.1). They use their descriptions from Day 13 for calculating surface area of rectangular prisms to develop a method for finding the surface area of a triangular prism. They consider triangular prisms where the triangles are equilateral, isosceles, and scalene.

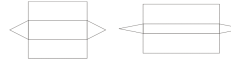

The general method:

$$\text{Surface Area} = 2 \times (\text{area of one triangle}) + (\text{areas of 3 rectangles})$$

Small Groups → Application

Groups use their method to find out how much material is required for the illustrated tent (include a floor). They provide a solution in two different metric units and include the labelled net. They record solutions for whole-class presentation.

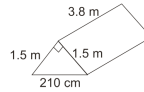

Connecting/Application/Checklist: Assess students' ability to connect and apply their understanding of rectangular prisms to triangular prisms.

Consolidate Debrief

Whole Class → Discussion

Small groups present their solutions, explaining the method they used. How does the method change if the prism has no top or bottom, i.e., the tent is open on one or both ends?

How can the method be simplified if the prism has:

- 3 congruent faces (the triangle is equilateral)?
- 2 congruent faces (the triangles are isosceles, like the tent example)?

Use the GSP[®] 4 file Nets (see Day 13) to make observations about how the net changes when dimensions are changed.

Home Activity or Further Classroom Consolidation

Complete one of the following tasks:

- In your journal, describe how the general method for calculating surface area of a triangular prism can be changed if the triangular faces are: a) equilateral, b) isosceles, or c) scalene. Use diagrams to illustrate your description.
- Practise finding the surface area of triangular prisms by completing worksheet 4.14.2.
- Describe an everyday situation where finding the surface area of a triangular prism is needed. Determine the dimensions. Find the surface area. Include a

Differentiated

See *Think Literacy: Cross Curricular Approaches – Mathematics*, p. 86.

Use TABS+ software to further create and investigate nets or use the GSP[®] 4 file Nets (see Day 13) for adjustable nets of triangular prisms.

Give each group a set of polydrons or nets to help them visualize during discussions.

Note: Peak of tent makes a right angle and the tent has a floor.

For students who are having trouble determining the height of the triangle, rotate the prism to visualize the triangle differently, or make a scale diagram and measure height.

Give students opportunities to progress through different representations (concrete → diagrams → symbolic) – formulas are not required, individually developed methods using the net is expected.

labelled diagram and a net.

| |

4.14.1: Triangular Prism Net (Scalene)

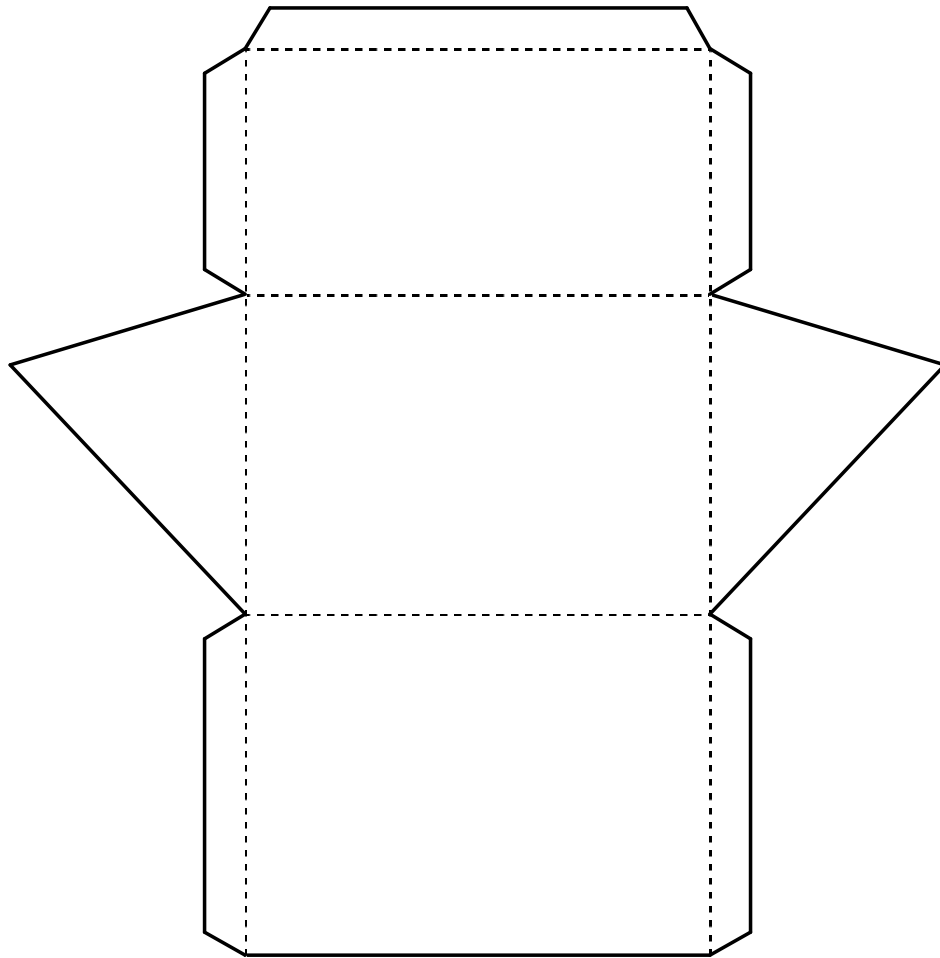

4.14.2: Surface Area of Triangular Prisms

Show your work. Explain how you solved the problem.

1. Determine the minimum amount of plastic wrap needed to cover the cheese by finding the surface area of the prism. Why might you need more wrap?

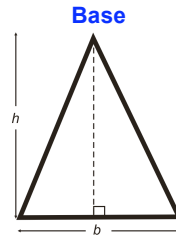
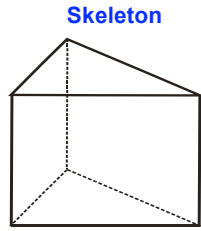
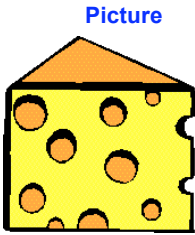

height of prism = 5.0 cm
length of rectangle = 6.3 cm

h = height of triangle = 6.0 cm
 b = base of triangle = 4.0 cm

Draw and label the net:

2. Determine the surface area of the nutrition bar.

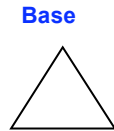
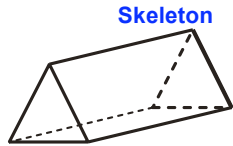
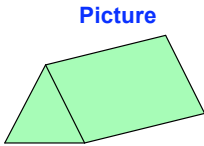

Length of rectangle = 5.0 cm

Equilateral triangle with:
height = 3.0 cm
base = 3.5 cm

Draw and label the net:

4.14.2: Surface Area of Triangular Prisms (continued)

3. Determine the surface area of the tent.
The front of the tent is an isosceles triangle. The tent has a floor.

Create a problem involving the surface area of the tent.

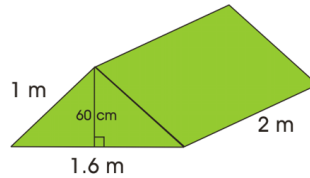

4. a) This "A-Frame" ski chalet needs to have the roof shingled. Determine the surface area of the roof.

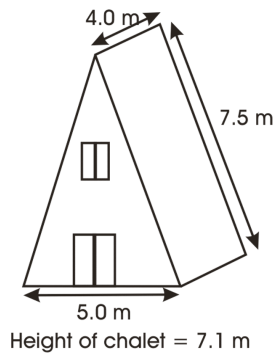

Hint:
Think about whether the height of the chalet is the same as the height of the prism. Which measurements are unnecessary for this question?

- b) Express the surface area of the roof in square metres and square centimetres.
- c) If the shingles were 35 cm long and 72 cm wide, how many would you need to cover the roof? Assume there is no overlap in shingles.

	<p>Math Learning Goals</p> <ul style="list-style-type: none"> • Students will determine the surface area of right prisms with parallelogram bases using concrete materials • Students will solve problems involving surface area (SA) of right prisms with parallelogram bases 	<p>Materials</p> <ul style="list-style-type: none"> • BLM 4.15.1 • Centicubes • Grid paper • Calculators
<p>Minds On...</p>	<p>Whole Class → Exploration</p> <p>The teacher will review the characteristics of all right prisms with the class.</p> <ul style="list-style-type: none"> - Top and bottom are congruent (same shape and area) - The sides create a 90° angle with the top and bottom - The sides of the prism are quadrilaterals. With one side of all the quadrilaterals the same dimension. <p>Review the formulas that were created for finding the surface area of rectangular and triangular prisms. Use BLM 4.15.1</p> <p>Ask students to:</p> <ol style="list-style-type: none"> 1) Find the perimeter of the base. 2) If the height of the prism is the same (which it will always be), then multiply it by the perimeter. What shape could be made with these dimensions? (Rectangle. Have students understand that the perimeter of the base can be described as a straight line) 3) Find the area of the base and the top of the prism. Will the area of both always be the same? (Yes, if it is a right prism) 4) Add both step 1 and 2 together. What do you notice about the solution? Will this always work? Explain why. <p>Record answers on the board. Create a formula using their responses.</p> <p>Surface Area of a right prism = height x perimeter of base + 2 x area of the base</p> <p>Students create a net for a parallelogram prism. The parallelogram has the dimensions of 7cm in length x 3 cm in height and slant height of 5 cm. The height of the prism is 8 cm. Have the students find its surface area using the perimeter of the parallelogram (Answer: SA=22 units²).</p>	<p>Do students know how to find the SA of triangular and rectangular prisms?</p> <p>Give students nets of the 3D prisms.</p> <p>Do students understand the difference between slant height and height of the shape?</p>
<p>Action!</p>	<p>Pairs → Investigation</p> <p>Students will create a parallelogram based prism for a chocolate bar company.</p> <p>Marshmallow Mountain Chocolate Company is looking to create some new packaging for their 10th Anniversary Chocolate Bar. They have decided to use a parallelogram-based prism instead of their regular rectangular based prism. Create the packaging that will best fit the chocolate bar measurements.</p> <p>Present your packaging and your rationale to the class.</p>	<p>Students choose their own measurements of the chocolate bar.</p> <p>Students can use computer software to create the nets</p>
<p>Consolidate Debrief</p>	<p>Whole Class → Discussion</p> <p>Students will present their packaging to the class and explain how they found the surface area of the parallelogram-based prism. They will also justify their choice of measurements for the packaging.</p> <p>Sample responses:</p> <p>“I chose to make my box 2 cm bigger on all sides to avoid the chocolate touching the side.”</p> <p>“I allotted for tin foil wrapping or a prize”</p>	
<p><i>Concept Practice</i></p>	<p>Home Activity or Further Classroom Consolidation</p> <p>Pose the following question:</p> <p>You decide to slice a rectangular based prism into two triangular based prisms. If you were to rearrange it to make a parallelogram based prism, would it increase, decrease or have the same surface area as the rectangular based prism? Explain your thinking.</p>	

4.15.1: Application of Right Prisms with Parallelogram Bases

Grade 7

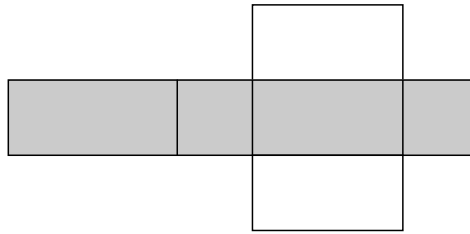
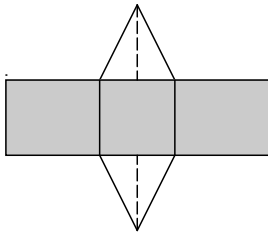
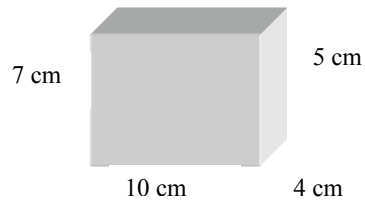
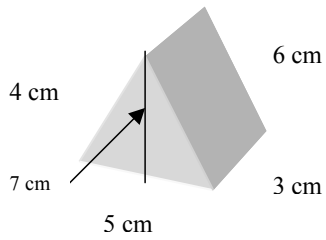

1. How does knowing the perimeter of the base of a right prism help find the surface area? Use nets to help explain your reasoning.
2. Myles was measuring a parallelogram-based prism. He found the dimensions to be 7 cm by 5 cm by 3 cm and the height of the parallelogram to be 4 cm. He concluded that the surface area of the prism was 84 cm^2 . Is he correct? If so, prove it. If not, explain what he did wrong and correct the mistake. Show the calculations and explain with words.
3. Describe an everyday situation where finding the surface area of a parallelogram based prism is needed. Determine the dimensions. Find the surface area. Include a labelled diagram and a net.



Learning Goals

Students will determine the surface area of right prisms with trapezoid bases using concrete materials
 Students will solve problems involving surface area of right prisms with trapezoid bases

Materials

- Geoboard
- Calculators
- Toothpicks

Minds On...

Whole Class → Exploration

Teacher reviews with the class the characteristics of all right prisms.

- Top and bottom are congruent (same shape and area)
- The sides create a 90° angle with the top and bottom
- The sides of the prism are quadrilaterals. With one side of all the quadrilaterals the same dimension.

Review the formulas that were created for finding the surface area of rectangular, triangular, and parallelogram right prisms.

Surface Area of a right prism = height x perimeter of base + 2 x area of the base

Students will create a net for a Trapezoid right prism using the geoboards or toothpicks. The Trapezoid has parallel side dimensions of 7cm and 6cm, has the height measuring 3 cm and a slant height of 5 cm. The height of the prism is 8 cm. Have the students find its surface area using the perimeter of the parallelogram (SA= 42.5 units²).

Do students know how to find the SA of triangular, rectangular, and parallelogram prisms?

Give student nets of the 3D prisms.

Do students understand the difference between slant height and height of the shape

Action!

Pairs → Investigation

The Royal Canadian Mint is commemorating the 2010 Winter Olympics by creating gold chocolate bars. The RCM is holding a contest to see who can create the most original Canadian packaging for the bars. The bars are in the shape of a trapezoid based right prism. Create the packaging that will best fit the chocolate bar measurements. Present your packaging and your rationale to the class.
 Students will include a net and a 3-D shape as part of the product.

Students choose their own measurements of the chocolate bar.

Students can use the computer software to create the nets for the prism

Consolidate Debrief

Whole Class - Discussion

Students will present their packaging to the class and explain how they found the surface area of the trapezoid based prism. They will also justify their choice of measurements for the packaging.

Sample responses:

- “I made my box 2 cm bigger on all sides to avoid the chocolate touching the side.”
- “I allotted an informational foldout pamphlet about Canadian Olympiads.”

Exploration

Home Activity or Further Classroom Consolidation

Use the internet and other resources to find out the reason why gold bars are in the shape of trapezoid right prisms.

If you made one slice through a parallelogram-based prism and rearranged it to make a trapezoid based prism, would it increase, decrease or have the same surface area as the parallelogram based prism? Explain your thinking.

Unit 4: Day 17: Surface Area of Prisms Whose Bases Are Composite Figures

Grade 7



Math Learning Goals

- Build prisms with bases that are composite figures.
- Develop a method to calculate surface area of prisms with bases that are composite figures.
- Solve problems that require conversion between metric units of area.

Materials

- overhead of BLM 4.17.1
- construction paper
- scissors
- tape, glue
- geosolids

Minds On...

Whole Class → Discussion

Students describe basic building designs in terms of prisms, e.g., a house with a peaked roof might be described as a rectangular prism topped with a triangular prism.

Show students a picture of a house, which is two prisms put together. Use geosolids to demonstrate how two prisms can be joined to form one solid.

Small Groups → Brainstorm

Brainstorm a list of objects that are made up of two or more right prisms.

Whole Class → Sharing

Compile a list of familiar objects that are combinations of right prisms. Students make quick sketches to illustrate their object.

Discuss how surface area would be calculated for a composition of more than one solid.

Students should recognize the method is the same as for rectangular and triangular prisms.

Action!

Pairs → Calculating Surface Area

Explain the task on BLM 4.17.1, identifying that the T is a composite figure made from rectangles. Students work in pairs on their design and calculation of surface area.

Students suggest several different methods for decomposing the T from BLM 4.17.1 into smaller rectangles in order to calculate its area.

Some students may wish to use computer software to design the polygon face of their letter.

Connecting/Application/Checklist: Assess students' ability to connect and apply their understanding of rectangular prisms to prisms with polygonal bases.

Consolidate Debrief

Whole Class → Four Corners

Pre-select four students to display models of different sizes. The students each move to a different corner of the classroom. Students with models of similar sizes to those in the 4 corners regroup together and compare their surface area solutions. Students review other pairs' calculations and suggest revisions.

Home Activity or Further Classroom Consolidation

In your journal reflect on what you found the hardest, the easiest, the most interesting, the least interesting about your study. Write a question that you still have about the surface area of prisms.

Complete questions that require you to find the surface area of prisms with composite shapes.

Reflection

Assessment Opportunities

Any composite shape can be made into a right prism. Use the method on BLM 4.12.4 to sketch a right prism with any type of polygon base. Help students to visualize that the prism can be viewed lying down or sitting upright.

To find the surface area, students must be able to visualize and draw the net and apply the formulas for area of 2-D shapes.

Other letters of the alphabet are suitable for this activity (I, L, C, F, H, U, V). You may wish to choose a letter that is more appropriate to your school name, or allow students to create their own initials.

Surface areas will not be the same, but should be approximately equal in models of the same size.

Provide students with appropriate questions.

Include prisms with trapezoidal bases.

4.17.1: Designing a Gift Box

The students at Trillium School want to design a gift box in the shape of a “T” to present to a guest speaker. They want to use heavy cardboard for each of the faces.

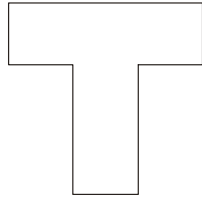

The finished gift box will look like this:

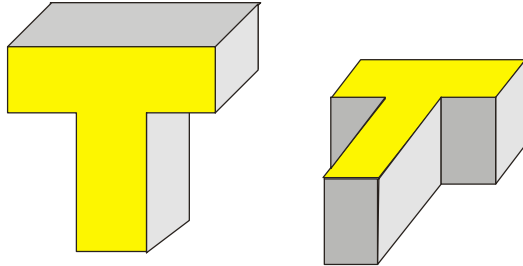

Your Task

1. Design and build the gift box. Choose dimensions in cm.
You may create a net with all of the faces attached, or you may build the prism by adding one face at a time. Tape the faces together.
2. Provide an explanation of your design on a piece of paper. Include:
 - a) a net of your gift box drawn on dot paper. Label the dimensions on your diagram.
 - b) a method for calculating the total surface area of your box.
 - c) the calculation for the amount of cardboard needed to make the gift box. Assume no overlap.

Extension

If the students at Trillium School decide to make a large wooden storage box in the shape of a T for the Kindergarten playground, determine possible dimensions, surface area and amount of paint required to cover the surface if 1 litre of paint covers 12 m^2 .

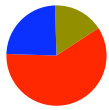

Math Learning Goals

- Demonstrate understanding of surface area of prisms with polygon bases.

Materials

- geosolids
- BLM 4.18.1

Assessment Opportunities

Minds On...

Whole Class → Brainstorm

Students discuss the decomposition of complex solids. Make geosolids available as a visualization aid. Use an example of a triangular prism roof sitting on a rectangular prism base.

Action!

Individual → Application

Discuss the instructions on BLM 4.18.1. Students complete the task individually.

Curriculum Expectations/Application/Checkbric: Assess students' ability to find the surface area of right prism with a polygonal base.

Students can highlight to mark the corresponding instructions on BLM 4.18.1 as you describe the assessment.

Give students an opportunity to clarify instructions.

Consolidate Debrief

Whole Class → Reflection

Students share their methods and results orally.

Access Prior Knowledge

Home Activity or Further Classroom Consolidation

In your journal, continue the following multiplication pattern, then calculate the value of each term of the sequence. Continue the pattern for 12 terms.

$1 \times 1, \quad 2 \times 2, \quad 3 \times 3, \dots$

Using your results estimate:

$3.4 \times 3.4 \doteq \underline{\hspace{2cm}}$

$6.7 \times 6.7 \doteq \underline{\hspace{2cm}}$

Check with a calculator, and reflect on how close you are.

The Home Activity will help prepare for the next lessons on squares and square root.

4.18.1: Tents

Camper's Choice!

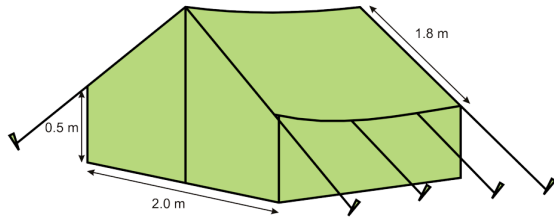

This two-person tent comes in a variety of colours. We recommend choosing a lighter colour that will not attract mosquitoes. Our tents are totally waterproof. This unique design allows occupants plenty of room for two sleeping bags and gear. You can even stand in this tent!

Floor of tent: 2.0 m x 3.0 m
 Center Height: 2.0 m
 Straight Side Height: 0.5 m
 Slant height: 1.8 m
 Price: \$210.00
 Item No. 39583749

Use the information on this advertisement to determine:

1. The amount of material used to make the tent
2. The amount of floor space per person

Assessment Checkbric

Criteria	Level 1	Level 2	Level 3	Level 4
Computing and carrying out procedures				
Integrating narrative and mathematical forms				
Representing a situation mathematically				
Selecting and applying problem-solving strategies				

	<p>Math Learning Goals</p> <ul style="list-style-type: none"> • Students will use the area of a square to represent perfect squares and square roots using geoboards and grid paper • Students will relate square root to the side length of square with area that is a perfect square number, e.g. connect a square with area 49cm^2 and side length 7 to the square root of 49 being 7 • Students will create the pattern of perfect squares (e.g., 4, 9, 16, 25, 36, 49...) and their square roots 	<p>Materials</p> <ul style="list-style-type: none"> • BLM 4.19.1 • Geoboards • Grid Paper
<p>Minds On...</p>	<p>Whole Class → Exploration</p> <p>Students will use geoboards to make different size squares. Students will find the area of each of those squares.</p> <p>Guide the students with the following question: What do you notice about the lengths of the sides of all the squares? They may respond stating that they are all whole numbers. Explain to the students that they have just discovered a perfect square.</p>	<p>Do students have an understanding of what a square is?</p> <p><i>Definition:</i> Perfect square : a number that can be expressed as the product of two identical natural numbers</p>
<p>Action!</p>	<p>Pairs → Investigation</p> <p>Students will complete the following problem and show their work on the geoboard.</p> <p>Myles has a backyard that has an area of 63m^2. He wants to put a square deck in his backyard. What are the possible areas and the length of sides of his deck?</p>	
<p>Consolidate Debrief</p>	<p>Whole Class → Discussion</p> <p>Students will share their answers to the problem with the class.</p> <p>Ask students: Can you find a pattern with the area of the decks? Can you find a pattern with the lengths of the decks?</p> <p>Discuss with students that what they have found in this problem is the square root of a perfect square.</p>	<p>Are students making a connection to the sides of the square to its area?</p>
<p><i>Concept Practice Exploration</i></p>	<p>Home Activity or Further Classroom Consolidation</p> <p>Hand out BLM 4.19.1 Students will play a game: Roll 3 – 6 sided number cubes and create a 3-digit number. The first student to find the closest perfect square to the number and the square root of the perfect square gets a point.</p>	<p>Create a chart of systematic trial and error (see BLM 4.19.1)</p>

4.19.1 Finding Perfect Squares using Systematic Trial and Error

Grade 7

Roll 3 six-sided number cubes to create a three-digit number. Record your guesses in the chart below. Alternate guesses with your partner. The student that guesses the closest perfect square gets a point.

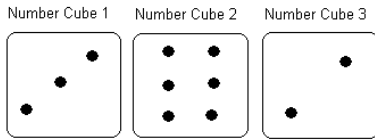

For example: The students roll 362.

Student 1: I predict 15. $15 \times 15 = 225$. Too low.

Student 2: I predict 20. $20 \times 20 = 400$. Too high.

Student 1: I predict 17. $17 \times 17 = 289$. Too low.

Student 2: I predict 18. $18 \times 18 = 324$. Too low.

Student 1: I predict 19. $19 \times 19 = 361$. Too low but 19 is the closest perfect square to 362.

I get a point! The square root of 361 is 19!

Prediction	Solution	Answer	Too high? Too low?
15	15×15	225	Too low
20	20×20	400	Too high
17	17×17	289	Too low
18	18×18	324	Too low
19	19×19	361	Too low

Let's Play!

Prediction	Solution	Answer	Too high? Too low?

Prediction	Solution	Answer	Too high? Too low?

Prediction	Solution	Answer	Too high? Too low?

Unit 4: Day 20: Perfect Squares and their Square Roots

Grade 7



Math Learning Goals

- Given the area of a square with sides that are not perfect square measures, students will estimate and calculate the length of the sides.
- Grade 7 will find the square roots of non-perfect squares, e.g. the square root of 50 will be slightly more than the square root of 49.
- Students will use a calculator to determine exact values for square roots of non-perfect squares.

Materials

- BLM 4.20.1
- Geoboards
- Grid paper

4.20.1 Finding Perfect Squares using Systematic Trial and Error

Grade 7

Roll 2 six-sided number cubes to create a two-digit number. Record your guesses in the chart below. Alternate guesses with your partner. The student that guesses the closest perfect square gets a point.

For example: The students roll 45.

Student 1: *I predict 6.0* $6 \times 6 = 36$ (Too low)

Student 2: *I predict 7.0* $7 \times 7 = 49$ (Too high)

Student 1: *I predict 6.5* $6.5 \times 6.5 = 42.25$ (Too low)

Student 2: *I predict 6.9* $6.9 \times 6.9 = 47.61$ (Too high)

Student 1: *I predict 6.7* $6.7 \times 6.7 = 44.89$ (Too low)

Student 2: *I predict 6.71* $6.71 \times 6.71 = 45.02$ (Too high but is the closest to two decimal places)

Prediction	Solution	Answer	Too high? Too low?
6.0	6×6	36	Too low
7.0	7.0×7.0	49	Too high
6.5	6.5×6.5	42.25	Too low
6.9	6.9×6.9	47.61	Too high
6.7	6.7×6.7	44.89	Too low

Let's Play!

Prediction	Solution	Answer	Too high? Too low?

Prediction	Solution	Answer	Too high? Too low?

Prediction	Solution	Answer	Too high? Too low?



Math Learning Goals

- Research and report on everyday applications of area measurements (in the form of a project).

Materials

- catalogues
- BLM 4.21.1

Assessment Opportunities

Minds On...

Small Group → Pass the Paper Game

In groups of four, students pass a paper for two minutes. In 15 seconds, each student adds to the list a 3-D object that has a different shape than those already listed. Students may “pass” once.

Whole Class → Brainstorm

Students create a brainstorming web about where 3-D design and construction is used in the community, e.g., computer graphics, architecture, artwork, model replicas, sculptures, film.

Students can further brainstorm about careers that would use 3-D designs.

Refer to *Think Literacy: Mathematics, Grades 7–9*, p. 78 for web samples.

Action!

Individual → Project

Describe the projects that students will complete during the next three days.

1. Research and report on a career that uses 3-D shapes.
2. Create a catalogue of ten 3-D shapes.
3. Design a playground.

Students choose one of three projects to complete.

Curriculum Expectations/Demonstration/Rubric: Assess students’ ability to research and report on applications of 3-D shapes.

Learning Skills/Observation/Checkbric: Observe students’ initiative and ability to work independently to complete a task.

Students studied volume of rectangular and triangular prisms in Grades 5 and 6. Some students may wish to include volume in their projects.

Students can choose the Internet or library as sources for their research.

Instructions for constructing a pentagon using GSP®4 can be found in Unit 8, Day 5, BLM 8.5.1.

Consolidate Debrief

Whole Class → Sharing

Describe activities and classroom procedures for the next two classes, during which students will work independently to complete their projects.

Some students present their plans and other students contribute suggestions, e.g., names of people who could be interviewed, resources for books.

Think Literacy: Mathematics, Grades 7–9, p. 86

Reflection Planning

Home Activity or Further Classroom Consolidation

Write a journal entry about your research plan for the next two classes. Include a list of the steps you will take and the materials you will need. Add a timeline that will help you to keep on task as you work on your project.

4.21.1: Three Dimensional Shapes – Projects



Create a Store Catalogue

You work for a company that sells a variety of three-dimensional objects through its catalogue. Part of your job is to produce the annual catalogue used to advertise your company's products.

Each item in the catalogue includes:

- a picture or sketch of the three-dimensional item, including its dimensions
- a description of the item and its features
- a sketch of the net of the item
- calculation of surface area of the item, using two different metric area units
- calculation of footprint area of the item (i.e., the area of the base)
- the price of the item

Your finished catalogue must include five different items that are right prisms. At least two of the items must have bases that are composite figures.

Research a Career that Uses Three-Dimensional Drawings or Buildings

Choose a career that was brainstormed during the class discussion.

- Research and describe the career, using the web or the library. If possible, interview someone who has pursued this career.
- List and describe the skills for interpreting, drawing, or building three-dimensional shapes that are used in this career.
- Provide some typical sketches, diagrams, and calculations that might be created on the job.
- List other non-mathematical skills that are required to be successful in this career.
- Present your information using a poster, a play, a mock interview, or a video.



Design a Kindergarten Playground

Design a playground for young children.

- Draw a diagram of the floor plan for the playground. Label dimensions and calculate areas of four different shapes that are featured in the playground. Include two composite shapes.
- Design and build two unique three-dimensional models of right prisms that represent the climbing equipment.
- Calculate the surface area of the prisms, using two different metric area units.
- Prepare a brochure to circulate to families in the neighbourhood. In the brochure, display your floor plan, three-dimensional diagrams of your prism, play equipment, and descriptions of the features of your playground.
- Hand in all of your calculations on separate sheets of paper.
- Hand in your three-dimensional models.

